

## F111 Series 3 Ceiling-Mounted Commercial Media Air Cleaner

### SPECIFICATION DATA

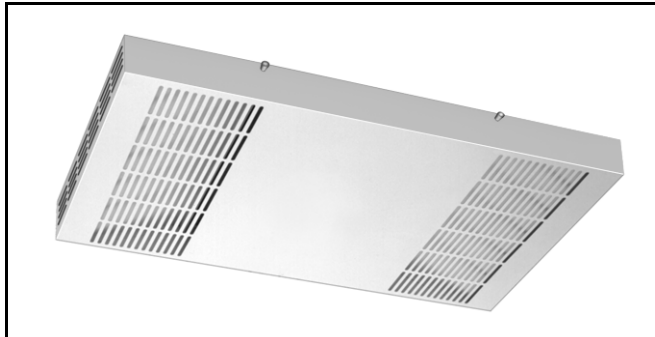

### FEATURES

- High Efficiency Particulate Air (HEPA) filter models are 99.97% efficient and the hospital grade particle filter models are 95% efficient at 0.3 micron particles. Both models are more efficient on particles smaller and larger. There is also a 95% ASHRAE model.
- Circulates up to 1250 cfm.
- Provides Coanda airflow distribution by drawing air from the room into the center of the room and discharging the air to both ends of the room.
- Designed to overcome the increase in airflow resistance normally caused by filter loading.
- White or black cover color complements ceiling color.
- CPZ module removes VOC and space odors for up to 24 months.
- 3-speed remote wall switch

### APPLICATION

The F111 Ceiling-Mounted Media Air Cleaner is designed for use in commercial applications that require the removal of airborne particles and odors. Typical applications include restaurants, bars, schools, offices, daycare centers, smoking lounges, and any indoor space where people meet, work or play. The F111 removes airborne particles such as dust, soot, and some cooking smoke from the air circulated through the filter.

The F111 uses a three-speed, direct-drive, forward curve blower motor with a high efficiency particulate arrestance (HEPA) filter that provides high-efficiency removal of particulates. When equipped with CPZ™ modules, the F111 also removes volatile organic compounds (VOC) and odor. This high filtration and adsorption efficiency enables the F111 to remove many of the troublesome particles, gases and odors from the indoor air.

Using the F111 to clean and recirculate indoor air can reduce the amount of outside air required to meet the ASHRAE ventilation standard. This results in lower energy costs because there is less outside air to condition.

### SPECIFICATIONS

**Models:** See Table 1.

**Cabinet Material:** Galvanized steel.

**Grill Color:** White or black color cover available.

**Electrical Ratings:**

Input Power: 120V, 60 Hz, 8.5A; 230V, 50 Hz, 4.2A.

Speed Connection: 3-Speed ( High, Medium, Low)

Motor: 1/2 hp, PSC three-speed.

**Airflow Pattern:** F111 draws room air into center of room and discharges air to both ends of room. This Coanda airflow pattern scrubs room corners for improved air cleaning and air circulation. See Fig. 1.

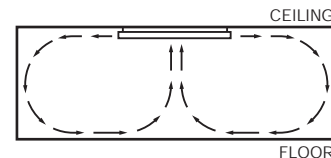

Fig. 1. Airflow pattern.

**Airflow:** 1250 cfm maximum, depending on filter configuration.

**Sound Rating at 3.3ft (1m):**

- Low Speed: 53 dBA.
- Medium Speed: 57 dBA.
- High Speed: 61 dBA.

**Primary Filter Options:**

- True HEPA filter 99.97% efficiency on .3 micron particles.
- Hospital Grade Filter 95% efficiency on .3 micron particles.
- 95% ASHRAE Filter

**Adsorption Module Options:**

CPZ™ Modules including (43 lbs):

- activated carbon.
- potassium permanganate.
- zeolite.

**Pre-filter:** Disposable.

**Dimensions:** See Fig. 2.

**Weight:** Shipping: 190 lb (86.1 kg).

**Installed:** 155 lb (70.1 kg) maximum.

**Mounting:** Recessed.

**Mounting Hardware:**

Four 3/8 x 16T internal nuts on cabinet top.  
All external hardware is installer supplied.  
Optional Z mounting bracket kit available.

**Approvals:**

Underwriters Laboratories Inc.: Listed.  
Canadian Standards Association: Certified.

**Accessories:**

- 190097C Remote 3-Speed Wall Switch
- 32002353 Z Mounting Bracket Kit.

**Replacement Parts:**

- 32000203-001 DOP Particle Filter.
- 32000204-002 99.97% HEPA Filter (4.75")
- 32004078-001 CPZ™ Module (requires two)
- 32004078-002 Activated Carbon Module (requires two)
- 32004078-004 Potassium Permanganate Module (requires two)
- 32004078-003 Zeolite Module (requires two)
- 50004739-001 95% ASHRAE Filter.

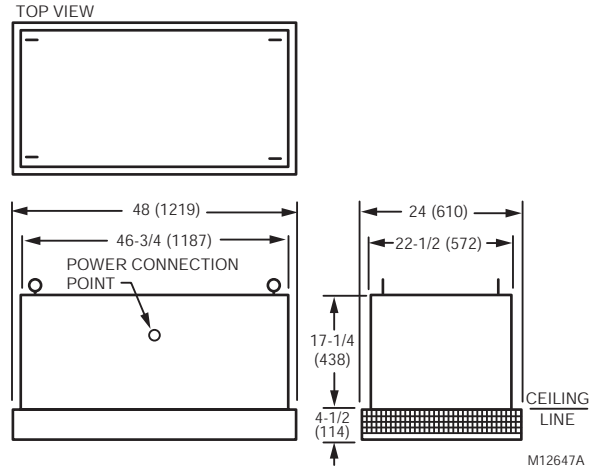

Fig. 2. F111 dimensions in in. (mm).

Table 1. F111 Model Description.

Model	Voltage	Efficiency	Gas VOC and Odor Control Modules (2)	Air volume in cfm (m <sup>3</sup> /hr)		
		Particulates at 0.3 micron		High <sup>a</sup>	Medium	Low
F111A1253W-3S	120 Vac, 60 Hz, 8.5A	95% ASHRAE	N/A	1250 (2120)	800 (1360)	450 (760)
F111A1063W-3S	120 Vac, 60 Hz, 7.2A	99.97% HEPA	N/A	950 (1610)	775 (1310)	450 (760)
F111C1073W-3S	120 Vac, 60 Hz, 7.5A	95% ASHRAE	CPZ™ modules	1150 (1950)	825 (1400)	450 (760)
F111C1003W-3S	120 Vac, 60 Hz, 7.0A	99.97% HEPA	CPZ™ modules	825 (1400)	700 (1190)	450 (760)
F111C1012W-3S	120 Vac, 60 Hz, 8.0A	95% at 0.3 micron	CPZ™ modules	1125 (1910)	825 (1400)	450 (760)
F111A2253W-3S	208/230 Vac, 50/60 Hz, 3.7A	95% ASHRAE	N/A	1125 (1910)	700 (1190)	475 (810)
F111A2007W-3S	208/230 Vac, 50/60 Hz, 3.7A	99.97% HEPA	N/A	900 (1530)	600 (1020)	400 (680)
F111C2073W-3S	208/230 Vac, 50/60 Hz, 3.7A	95% ASHRAE	CPZ™ modules	1025 (1740)	675 (1150)	450 (760)
F111C2003W-3S	208/230 Vac, 50/60 Hz, 3.7A	99.97% HEPA	CPZ™ modules	825 (1400)	550 (930)	375 (640)
F111C1053W-3S	208/230 Vac, 50/60 Hz, 3.7A	95% at 0.3 micron	CPZ™ modules	950 (1610)	625 (1060)	425 (720)

N/A = Not applicable.

<sup>a</sup>For single-speed and three-speed systems (set to High)

**Air-Pure Systems**

16873 Fish Point Rd. SE  
Prior Lake, MN 55372-1714  
Phone: (800) 998-1919  
Fax: (800) 221-3248

