

F118 In-Ceiling Media Air Cleaner

PRODUCT DATA

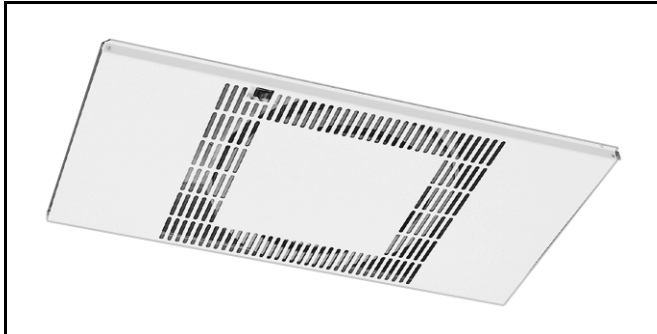

APPLICATION

The F118 In-Ceiling Media Air Cleaner uses a three-speed direct-drive, forward-curve blower motor and a 95 percent DOP particle filter to capture airborne particles such as dust, soot, and cooking smoke from the air circulated through it. When equipped with two CPZ™ modules, the air cleaner also adsorbs gases and odors from the air passing through it. The F118 is recommended for use in rooms with drop ceilings, and for spaces with structural ceilings not higher than 16 feet (4.8 meters) where there is a minimum one-foot (0.3 meter) clearance between the drop ceiling and the structural ceiling.

The air cleaner is designed to use the Coanda effect to circulate air throughout the space. This effect is the tendency of air to travel close to a wall contour when ejected from a jet. The air cleaner draws contaminated air up from the center of the room, forces it through the filters, and then blows the filtered air out through the narrow ends of the air cleaner.

FEATURES

- The DOP particle filter is 95 percent efficient at 0.3 micron particles, and more efficient on particles smaller and larger.
- CPZ™ modules can reduce space odors.
- Circulates up to 425 cubic feet per minute (723 cubic meters per hour).
- Provides Coanda air distribution by drawing in dirty air, cleaning it, and bi-directionally recirculating the filtered air throughout the space.
- Designed to overcome the increase in air flow resistance normally caused by filter loading.
- White color cover complements the ceiling.
- Accessible three-speed pushbutton switch.
- Optional wall-mounted remote switch.
- Filters are easily removed and replaced.
- **READ AND SAVE THESE INSTRUCTIONS**

Contents

Application	1
Features	1
Specifications	2
Ordering Information	2
Planning the Installation	3
Installation	4
Operation	7
Service	8
Parts list	9
Limited Two-Year Warranty	12

SPECIFICATIONS

IMPORTANT

The specifications given in this publication do not include normal manufacturing tolerances. Therefore, this unit may not exactly match the listed specifications. Also, this product is tested and calibrated under closely controlled conditions, and some minor differences in performance can be expected if those conditions are changed.

Color: Galvanized steel cabinet and white cover.

Blower/Motor: Three-speed direct-drive forward curve. Motor lubrication is not required.

Ambient Temperature Rating:

Shipping and Storage: -20°F to +150°F (-29°C to +66°C).
 Operating: Ambient temperatures usually below 77°F (25°C) but occasionally as high as 104°F (40°C).

Humidity: Up to 95% relative humidity, non-condensing.

Air Volume:

	120V	230V
High	425 cfm, 723 m ³ /hr	400 cfm, 680 m ³ /hr
Medium	300 cfm, 510 m ³ /hr	320 cfm, 544 m ³ /hr
Low	200 cfm, 340 m ³ /hr	220 cfm, 374 m ³ /hr

Electrical Ratings:

Current Draw	120V	230V
High	2.8A	1.6A
Medium	2.0A	0.8A
Low	1.4A	0.5A

Grille Type: Perforated metal.

Dimensions:

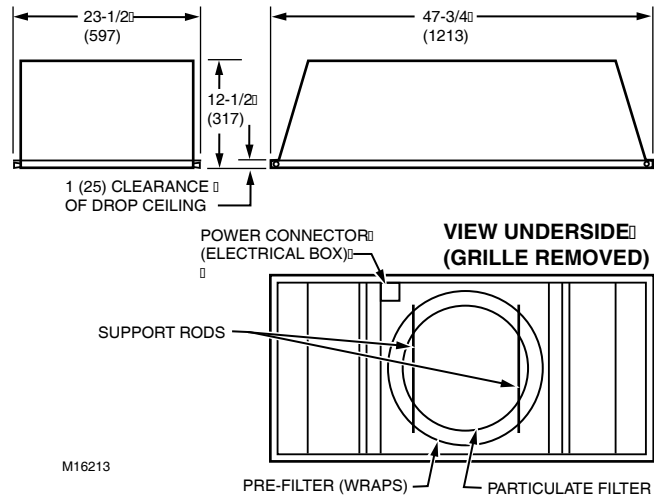

Fig. 1. Approximate dimensions of F118 in in. (mm).

Mounting:

Hangs freely from structural ceiling.
 Can be recessed into a drop ceiling frame.

Weight:

Shipping (Cabinet and Contents): 119 lb (54 kg).
 Installation: 92 lb (42 kg).
 CPZ™ Adsorbent Module: 8 lb (3.6 kg) each.
 Module Total Weight: 10 lb. (4.5 kg) each.

Sound Level at 3.3 ft (1m):

High Speed: 65 dBA.
 Medium Speed: 54.5 dBA.
 Low Speed: 48 dBA.
 Operation at low and medium speeds is within white noise range.

Approvals:

UL: Listed.
 CSA: Certified.
 CE: Pending.

Replacement Parts: See the Parts List section.

ORDERING INFORMATION

If you have additional questions, need further information, or would like to comment on our products or services, please write or phone:

- Your local Honeywell Commercial Air Products Distributor.**
- Air-Pure Systems**
 16873 Fish Point Rd. SE
 Prior Lake, MN 55372-1714
 Phone: (800) 998-1919
 Fax: (800) 221-3248

PLANNING THE INSTALLATION

The sizing procedure determines the number of F118 needed. The correct number required for a particular application depends on:

- type of contamination.
- number of occupants.
- room volume.
- room use.
- outdoor air quality.

Assuming that the structural ceiling height is no higher than 16 ft (4.8m), one F118 set on high speed cleans 425 cfm, 25,500 cf/hr (723 m³/hr). The number of air changes per hour determines the amount of air cleaning that occurs. Use the following formula to determine the required number of F118 Air Cleaners:

Area of room in cubic feet/air cleaner cubic feet per hour x desired number of air changes per hour.

For example, to compute the number of air cleaners that would be required to clean an area of 30,000 cubic feet, at the rate of four times per hour when operating on high speed: $(30,000/25,500 \times 4 = 4.7)$.

Result: This area requires five F118.

For the most efficient operation, place the F118 as close as possible to the contaminant source. For ambient air cleaning, it is essential to establish a uniform airflow pattern throughout the entire space. Physical limitations, such as the following, may change the number of air cleaners required:

- If there is insufficient mounting space, fewer air cleaners can be installed. If it is necessary to reduce the number of air changes per hour, bring in more outdoor air to maintain low contaminant levels.
- An irregularly shaped room does not allow even airflow, and may require more air cleaners.

For questions about determining the number of air cleaners needed, consult your local Honeywell Commercial Air Cleaner Distributor.

Choose Location

The air cleaner is designed to hang from a structural ceiling. It mounts horizontally, inside or outside of a drop ceiling system. It also fits between joists set 24 in. (610 mm) on center. When used with a drop ceiling system, allow at least 12 in. (305 mm) clearance between the structural and drop ceiling to allow space for the air cleaner. To ensure unobstructed airflow, the grille, which is one inch (25 mm) deep, must protrude below the drop ceiling surface.

The location and orientation of the air cleaner affects its performance. Mount it in a location that allows airflow to reach the extreme areas of the zone. See Fig. 2.

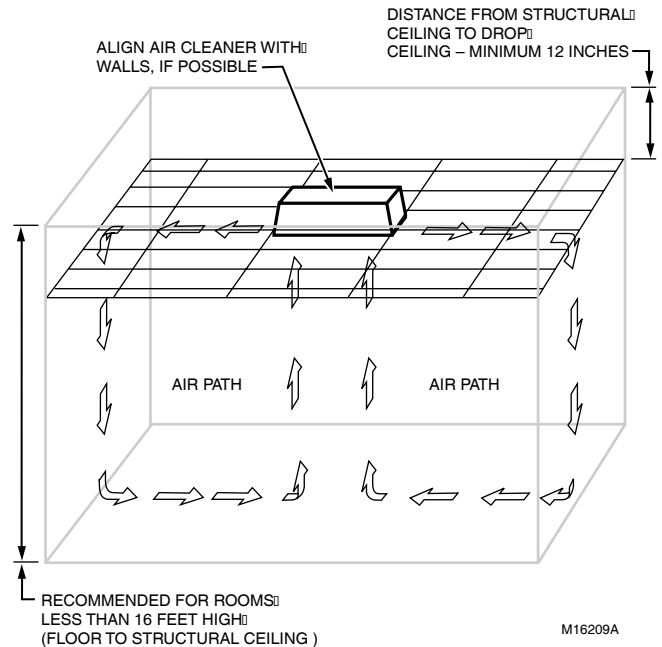

Fig. 2. F118 Air Circulation Schematic (Coanda Airflow).

The air cleaner is rectangular to align with the walls of any rectangular space. When installing an air cleaner in a rectangular space, place the length parallel with the room length and the width parallel with the room width.

When a room requires only one air cleaner, hang it in the center of the room.

Large rooms usually require more than one air cleaner. When using several, divide the entire space into equal volumes and distribute the air cleaners throughout the space so each air cleaner circulates similar air quantities. To ensure optimum performance of each air cleaner:

1. Use the formula above to determine the number of air cleaners required for the large room.
2. Visually divide the entire room into several cubic volumes. For example, if three air cleaners are to be installed, visualize the room as approximately three cubic volumes.
3. Consider each portion as a single room and install the air cleaner at the center of each area. Align the air cleaners to be parallel. See Fig. 3.

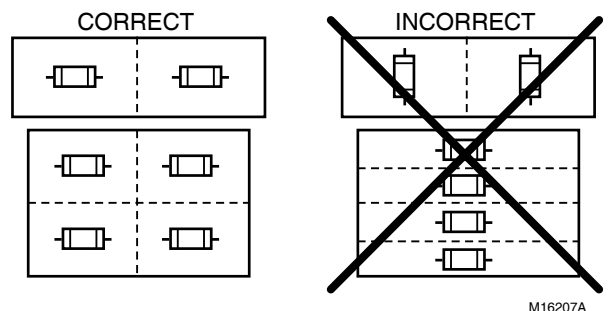

Fig. 3. Arranging air cleaners in a large area.

INSTALLATION

WARNING

Explosion Hazard.

Can cause personal injury or equipment damage.
Do not install or use the F118 Air Cleaner where there is any danger of a gas, vapor or dust explosion.
Do not install when explosion-proof electrical fixtures are specified.

WARNING

Fire or Electric Shock Hazard.

Can cause personal injury or equipment damage.
Turn off power source before installing or servicing air cleaner.
Do not use air cleaner in the ceilings of fire-resistant assemblies.

When Installing This Product . . .

1. Read these instructions carefully. Failure to follow them could damage the product or cause a hazardous condition.
2. Check the ratings given in the instructions and on the product to make sure the product is suitable for your application.
3. Installer must be a trained, experienced service technician.
4. After installation is complete, check out product operation as provided in these instructions.

Unpack Air Cleaner

WARNING

Sharp Edges.

Can cause personal injury.

Wear protective gloves and handle air cleaner carefully to avoid cuts from sharp metal edges.

The air cleaner is shipped assembled in a packing container. When unpacking, check that all air cleaner components are included.

1. Container:
 - Installation Instructions (1)
 - 12 Gauge wire (40 ft)
 - Support shoulders (8).
2. Assembled cabinet; consists of a cabinet frame and grille/door assembly:

- Blower/motor assembly (1).
- CPZ™ media module (2).
- Particulate filter (1).
- Pre-filter attachment clip (2).
- Pre-filter (1).

Use the following procedure to remove the grille and all contents of the cabinet, including the CPZ modules and filters.

1. Remove the grille:
 - a. Remove the bolts from the hinge that hold the grille to the cabinet.
 - b. Remove the bolts and the spring-loaded plungers at the other end of the cabinet.
 - c. Set aside the grille.
2. Remove the filters:
 - a. Pre-filter is wrapped around the particulate filter. Two support rods in the center bay of the cabinet hold the particulate filter and the pre-filter in place. Push these rods apart and lift the filters out of the cabinet.
 - b. Two CPZ sorbent modules wrapped in plastic are located at either end of the cabinet. Tilt each module to lift it from the cabinet. Set aside both modules.
3. Remove the cabinet from the container.
4. Remove all shipping cardboard and containers inside and outside of the air cleaner components.
5. Inspect the packing material to ensure that no parts or papers are lost.

The installer must supply the following additional items required for the installation:

1. Any external hardware such as extra nuts and bolts.
2. Leveling tool or method.

Make Opening (If Mounting in Drop Ceiling)

IMPORTANT

Be sure to choose an accessible position for the air cleaner. Check that the area directly below the position of the air cleaner is open and free and clear of obstructions.

See Fig. 4 and use these instructions to mount the F118 as part of a drop ceiling:

1. Remove the tile(s) from the drop ceiling to open a space of approximately 24 x 48 in. (610 x 1220 mm). The area between the drop ceiling and the structural ceiling must be at least 12 in. (345 mm) and clear of ducts, pipes, and other obstacles.
2. Size and frame the opening to fit the air cleaner cabinet as closely as possible. The cabinet must fit snugly in the opening; allow no more than 1/4 in. (6 mm) from the opening to each side of the cabinet.
3. Cover the framing and any unused portion of the opening with wallboard, plywood, or other material. Finish to match the ceiling.

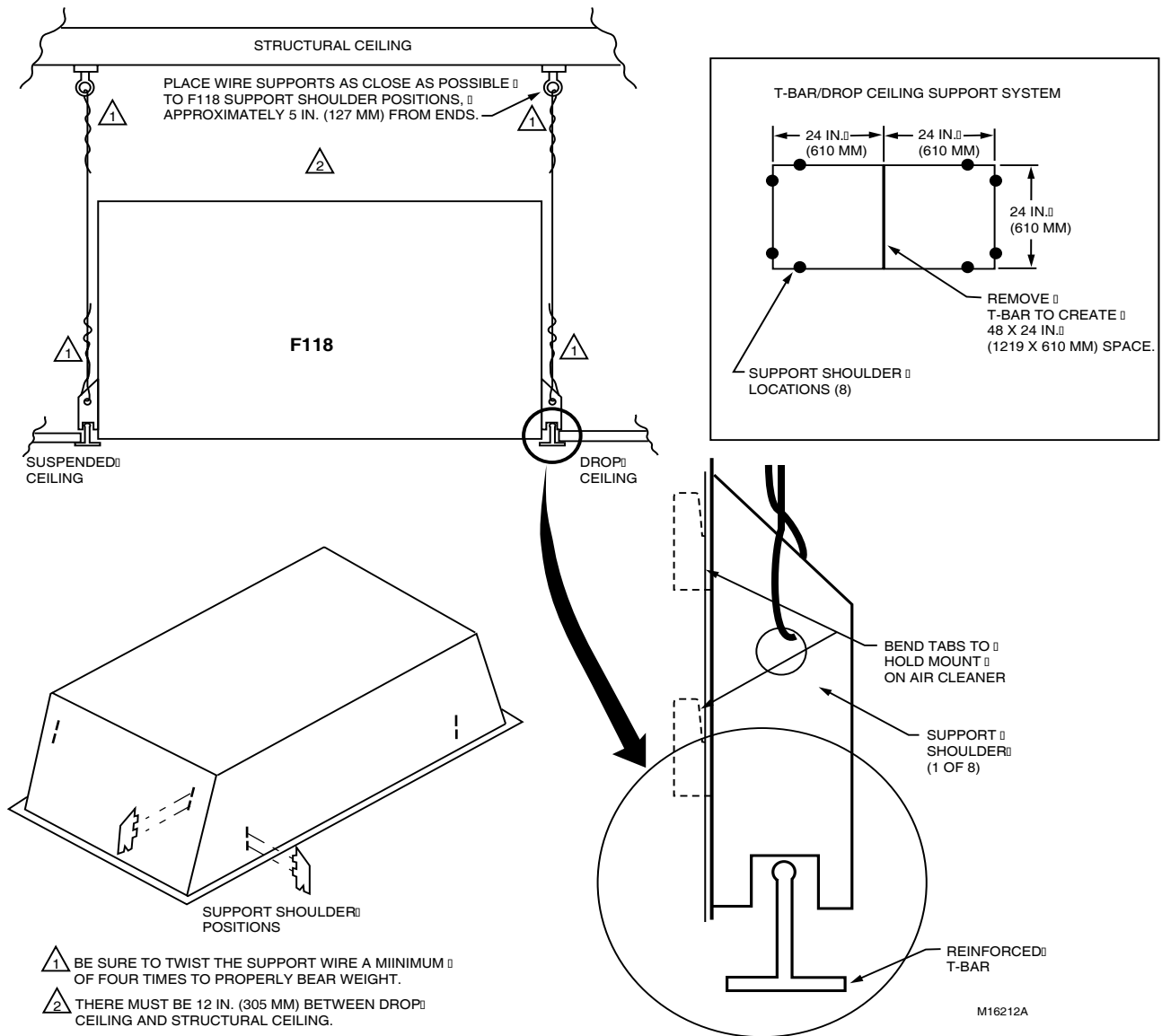

Fig. 4. Mounting procedure.

Mount Air Cleaner Cabinet

⚠ WARNING

Fire or Electric Shock Hazard.
Can cause personal injury or equipment damage.
 Do not connect the power source until after electronic air cleaner is mounted.

1. The cabinet has multiple slots. See Fig. 4. Insert the support shoulders into the selected slots.
2. Bend the two tabs on each support shoulder until the tabs are flush with the cabinet.
3. Thread wire through the support shoulders. Make sure the wire is strong enough to support the total weight of the air cleaner. Never rest the air cleaner on the T-bar unless it has been reinforced to hold the weight.
4. Twist the support wire a minimum of four times.

⚠ WARNING

Equipment Falling Hazard.
Can cause personal injury, structural weakening, buckling, or damage to equipment.
 Be sure platform is stable and can support combined weight of installer and equipment.
 Use assistant to help support equipment during installation.

5. Standing on a secure platform, lift the cabinet body and insert it into the frame in the drop ceiling.
6. Attach the free end of the wire to the structural ceiling. Align the cabinet edge with the upper side of the T-bars, without releasing the full weight onto the T-bars.
7. Verify that the wire is strong enough to bear the load of the F118 before completing installation.
8. Level the air cleaner.

Electrical Hookup

All wiring must comply with applicable codes and ordinances. The air cleaners are internally pre-wired.

IMPORTANT

Check that the air cleaner is grounded for proper operation and safety.

Canadian Installations: Do not install in ceilings with thermal insulation value greater than R-40.

If installing an additional wall switch to regulate the air cleaner speed, only the Honeywell 32000234 (41105) Variable Speed Switch (optional) is recommended. Using a different speed controller can void the warranty.

1. Pull the wire to the electrical box through the hole in the top of the cabinet. Refer to Fig. 5 and 6 for typical wiring diagrams.

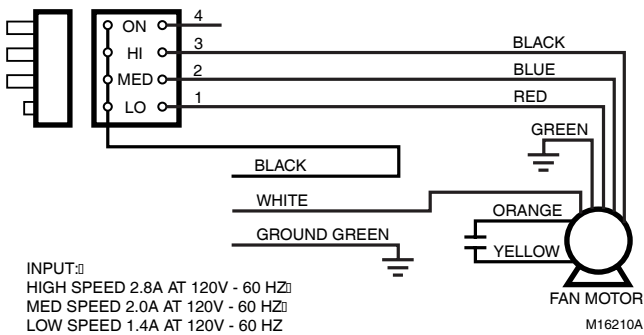

Fig. 5. Typical F118 120V, 60 Hz Wiring Diagram.

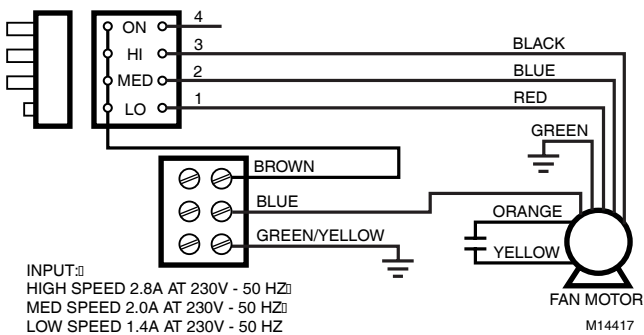

Fig. 6. Typical F118 230V, 50 Hz Wiring Diagram.

WARNING

Fire or Electric Shock Hazard.

Can cause personal injury or equipment damage.

Be careful performing electrical check when air cleaner is turned on.

Be careful when working near air cleaner moving parts.

2. Turn on air cleaner power and check for proper operation for two to three minutes. There should be a smooth, powerful blower sound with air discharging from both ends of the air cleaner.
3. Turn off the power.

Install Filters

CAUTION

Eye Exposure.

Harmful dust can obstruct or injure unshielded eyes.

CPZ module normally releases dust when handled. Always wear safety glasses when installing or removing CPZ module.

CAUTION

Filter Media Damage Hazard.

Damage to the filter media can easily occur.

Do not touch the pleated filter media.

Handle only the filter frame.

1. Install the particle filter and pre-filter that is wrapped around the particle filter:
 - a. Push aside the support rods.
 - b. With both hands, slide the filter up into the central portion of the cabinet and hold it in place.
 - c. Pull the support rods down and toward the center, until the filters are held in place and the weight completely supported.

IMPORTANT

Avoid excessive pressure on individual adsorbent panels.

1. Install the CPZ sorbent modules:
 - a. Remove CPZ™ sorbent modules from the packaging.
 - b. See Fig. 7 to install CPZ module at each end of the cabinet. Tilt and then push the module up about ten inches into the opening. Then allow it to rotate down so the bottom rests on the inside cabinet ledge.

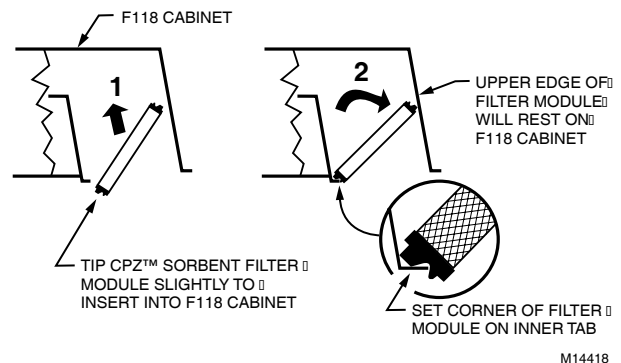

Fig. 7. Installing CPZ Modules.

Install Grille

When installed, the grille can travel down a radius of approximately 4 ft. (1m). It should be able to swing freely without office furniture or machinery obstruction. If unlatching the grille is a problem, replace the hinge hardware with the spring-loaded plungers so the grille opens in the opposite direction. See Fig. 8.

1. Select the preferred installation position for the grille.
2. Reinstall the lock nuts and bolts in the hinge corners.

3. Reinstall the spring-loaded plungers and hardware at the opposite end of the cabinet.
4. Close and latch the grille.

When installed and latched, the grille protrudes about one inch below the surface of the drop ceiling. Proper operation of the air cleaner requires that it be level.

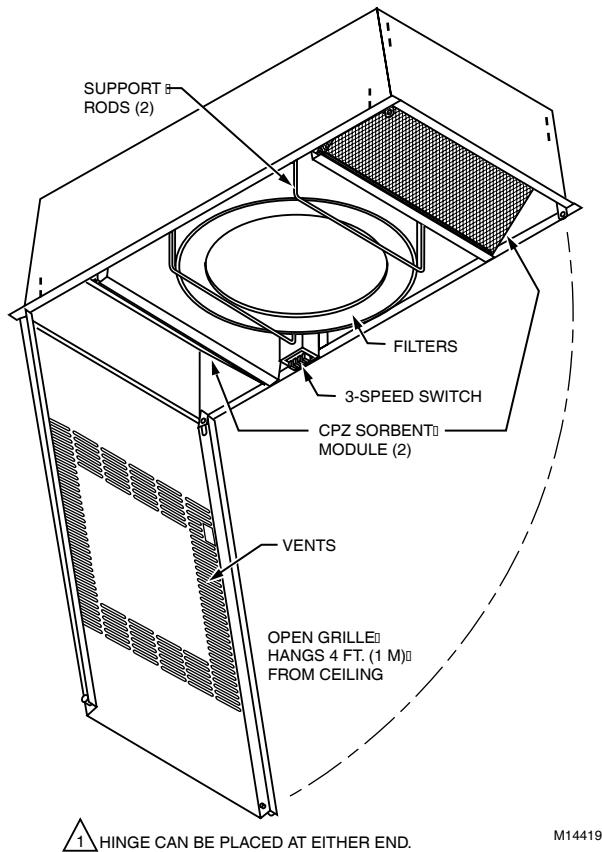
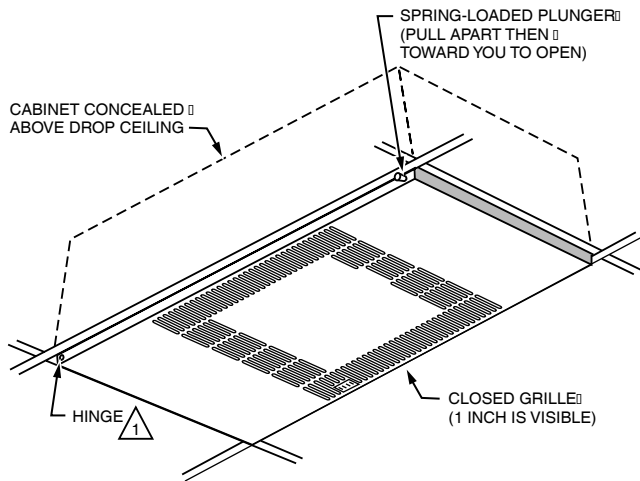

Fig. 8. Installing grille.

OPERATION

Local, Federal and professional ventilation engineering standards and codes prescribe minimum ventilation rates to dilute air contamination in specific applications. The ventilation rates usually assume the injection of outdoor air measured as air exchange rate.

Using the F118 Air Cleaner to comply with ventilation requirements is an acceptable alternative to ventilation with outdoor air. However, at least 20 percent of a specified ventilation code rate must be derived from outdoor air. The F118 Air Cleaner filtered and re-circulated air can supply the remaining 80 percent.

Airborne contaminants are always present in the air where contaminant generation occurs. Air cleaning systems and ventilators do not eliminate airborne contaminants; they reduce excessive contaminant accumulation. To eliminate the contamination, the source of contamination must be removed.

The F118 in Ceiling Media Air Cleaner was engineered to improve indoor air quality for commercial and industrial applications. The filters are effective for capturing atmospheric dust, mold spores, smoke, fumes, mists and aerosols. See Fig. 9.

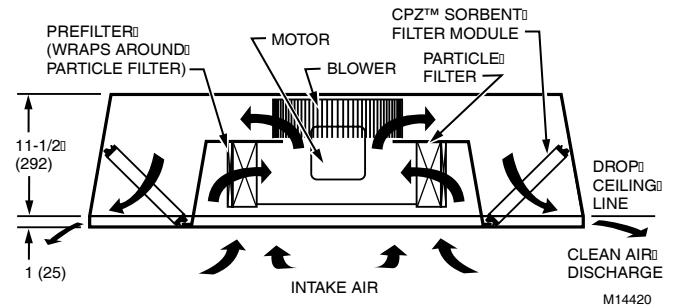

Fig. 9. F118 Air Cleaner operation.

The air cleaner may be operated on high, medium, or low speed, depending on the number of people and activities in the space.

The unit may be used only while people are using the room, or when contaminants from other sources must be removed from the room. And the air cleaner may be operated continuously to prevent buildup of airborne contaminants, even when the room is unoccupied.

The CPZTM sorbent module collects and holds gas-phase compounds and vapors typically found in commercial and light industrial facilities. These gases and vapors frequently appear as odors that can be annoying and irritating. CPZTM material extends the maintenance service life.

The minimum recommended air exchange rate is 2.5 times per hour. In a heavily contaminated area, up to 15 air exchanges per hour can be necessary. The factors that determine the rate of air exchange are:

- Generation rates of the various pollutants;
- Concentration level of the pollutants;
- Desired contamination reduction level.

SERVICE

WARNING

Fire or Electric Shock Hazard.
Can cause personal injury or equipment damage.
 Turn off power source before servicing air cleaner.

IMPORTANT

A very dirty filter reduces air cleaner airflow.

Opening/Closing Grille

IMPORTANT

Use this procedure when opening the grille to prevent damage to the cover and prevent ceiling buckling.

To open the grille and remove and replace the filters:

1. Pull apart the spring-loaded plungers to disengage from the grille.
2. Turn the plungers to keep them from closing and reengaging the grille.
3. Slide the grille forward toward you. It can travel about one inch.
4. Slowly and carefully allow the grille to swing down.

To close the grille:

1. Swing grille into the closed position.
2. Engage the plungers.

Particle Filter

The particle filter collects particles that are not trapped by the pre-filter. The particle filter life is from 6 to 24 months (typically 12 to 24 months). Change modules and filters more frequently in facilities that operate 24 hours a day. When the filter is loaded with contaminants, there is a pulsing sound, and decreasing air quality. Replace the filter when the pulsing sound becomes audible.

IMPORTANT

The filter must be removed and replaced. Washing, vacuuming or reverse air blasting does not clean it.

CAUTION

Equipment Damage Hazard.
Handling can damage the filter media.
 Handle only the filter frame.
 Do not touch the pleated filter media.

1. Push aside the two spring-loaded support rods that hold the filter frame in place.
2. Rotate the rods; the filter is released and can be removed.
3. With both hands, slide the filter toward you.
4. Place the removed filter in a plastic trash bag and dispose of properly.
5. Unwrap and install a new filter.

Motor

The motor is visible when the filter frame is removed. Inspect the motor brackets for loose fasteners; tighten as necessary.

Pre-filter

The disposable pre-filter collects large dust particles and lint-type airborne fibers. It is wrapped around the particle filter and held in place with two clips. Check the filter every two weeks. To change the pre-filter:

1. Wrap a new pre-filter around the new particle filter.
2. Attach the two new clips to hold the pre-filter in place. (New clips are supplied with pre-filter replacements.)
3. Position the filter frame in the air cleaner.
4. Pull down the spring-loaded support rods together, position over the filters and secure in place.

CPZ™ Adsorbent Module

The CPZ™ adsorbent module is used to collect gases, vapors, odors and volatile organic compounds (VOC) from the air that passes through the air cleaner. The impurities are collected until the adsorbents reach saturation, when a continuously strong pungent odor is emitted. If the air cleaner is turned off for eight to ten hours, a temporary odor is emitted when it is turned back on. If the odor persists for 30 minutes, it is time to replace the filters.

The useful life of the CPZ™ sorbent modules can vary from four to 24 months, depending on the application. In most applications, the sorbent media life ranges from 12 to 18 months. Change modules and filters more frequently in facilities that operate 24 hours a day.

NOTE: When tobacco smoke is a contaminant, both the particle filter and the CPZ adsorbent filter must be serviced at the same time.

CAUTION

Eye Exposure.
Harmful dust can obstruct or injure unshielded eyes.
 CPZ modules normally release dust when handled. Always wear safety glasses when installing or removing CPZ modules.

1. Tilt the module up from the inside cabinet lip.
2. Use both hands to lower the CPZ module down and out from the end of the cabinet.
3. Place the used module in a plastic trash bag and dispose of properly.
4. Unwrap new CPZ™ sorbent modules and install.

IMPORTANT

Avoid excessive pressure on individual adsorbent panels.

NOTE: Upon initial startup, a small amount of dust can blow from the air cleaner. This is normal and stops a few minutes after startup.

PARTS LIST

See Fig. 10.

No.	Description	Pack Qty.	Order Number
1	CPZ™ sorbent module (2)—used only with DOP particle filters.	2	32004079
2	DOP primary particle filter, 95 percent (1).	1	32002272
3	Pre-filter (disposable) (1).	1	32002590
4	Blower wheel (1).	1	32002269
5	Motor assembly (1), 120V.	1	32002268
	Motor assembly (1), 230V.	1	32004512
	Motor mount.	1	32002589
6	Inlet cone (1).	1	32002286
7	Grille assembly, without hinges and latches (1).	1	32002266
8	3-speed switch.	1	190382
9	Spring loaded plunger (2).	2	32002278
MISCELLANEOUS / OPTIONAL PARTS			
	Motor maintenance grommet set (1)—(not illustrated).	3	32000261
	Optional 3 speed switch wall mount remote switch (1)—(not illustrated).	1	190097C
INSTALLATION PARTS INCLUDED (Not Shown)			
	Shoulder mounts (8) - (not illustrated)	1	196133

() = Quantity required per unit.

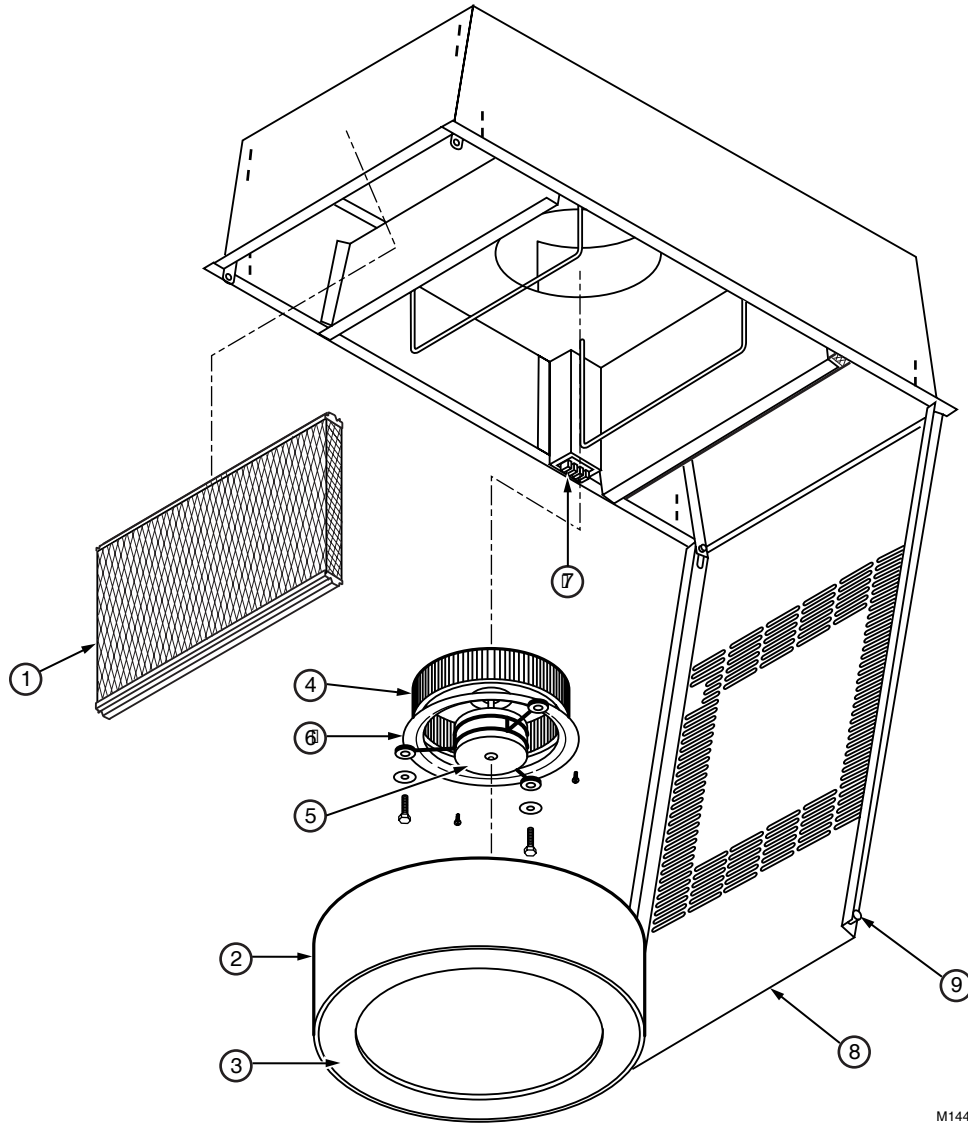

M14421

Fig. 10. F118 Air Cleaner components.

NOTES

LIMITED TWO-YEAR WARRANTY

Air-Pure Systems warrants its air cleaner products to be free from defects in workmanship or materials under normal use and service, for a period of two (2) years from the date of purchase by the original end-user. If at anytime during the warranty period the product is defective or malfunctions, Air-Pure Systems, through the distributor or dealer, from which the product was purchased, or through an authorized warranty repair station, shall at Air-Pure Systems option, replace or repair the defective product or component.

This warranty does not cover removal or installation costs. This warranty shall not apply if it is shown that the defect or malfunction was caused by damage which occurred during handling or shipment, improper electrical connections, improper use of the product or abuse.

Air-Pure Systems sole responsibility shall be to repair or replace the product within the terms stated above. **AIR-PURE SYSTEMS SHALL NOT BE LIABLE FOR ANY LOSS OR DAMAGE OF ANY KIND, INCLUDING ANY INCIDENTAL OR CONSEQUENTIAL DAMAGES RESULTING, DIRECTLY OR INDIRECTLY, FROM ANY BREACH OF WARRANTY, EXPRESS OR IMPLIED, OR ANY OTHER FAILURE OF THIS PRODUCT.** (Some states do not allow the exclusion or limitation of incidental or consequential damages, so this limitation may not apply to you.) **THE WARRANTIES SET FORTH HEREIN ARE EXCLUSIVE AND AIR-PURE SYSTEMS EXPRESSLY DISCLAIMS ALL OTHER WARRANTIES, WHETHER WRITTEN OR ORAL, IMPLIED OR STATUTORY, INCLUDING BUT NOT LIMITED TO ANY WARRANTIES OF MERCHANTABILITY, WORKMANSHIP, OR FITNESS FOR A PARTICULAR USE.**

This warranty gives you specific legal rights and you may have other rights which vary from state to state.

How to make a warranty claim or have questions answered:

Should you have a warranty claim or questions about the warranty policy, contact the distributor or dealer from which you purchased the product or the authorized warranty repair stations nearest your location.

NOTE: Do not return any products or parts to the factory without a factory issued "Returned Warranty Goods Label" issued by Air-Pure Systems.

In the event you or other persons, have any questions concerning the use and care of this product or this warranty please call or write the factory.

Air-Pure Systems
16873 Fish Point Rd. SE
Prior Lake, MN 55372-1714
Phone: (800) 998-1919
Fax: (800) 221-3248

Air-Pure Systems.
16873 Fish Point Rd. SE
Prior Lake, MN 55372-1714
Phone: (800) 998-1919
Fax: (800) 221-3248