

F116 Series 2 Self-Contained Ductable Commercial Air Cleaner

PRODUCT DATA



APPLICATION

The F116 Series 2 Self-Contained Ductable Commercial Air Cleaner is a media air cleaner that uses a three-speed direct drive forward curve blower/motor with a variety of filter combinations to remove airborne contaminants. The air cleaner is designed to provide its own air circulation. In addition it can accommodate ducting which can be attached to the intake and/or the outlet of the cabinet as the application requires.

The air cleaner is suitable for the collection of smoke, bacteria and viruses, gases, odors and volatile organic compounds (VOCs), fine saw dust, paper dust, brazing, normal atmospheric dusts such as pollens, allergens, dust mites and soot, and virtually any other respirable airborne contaminant. When equipped with CPZ™ modules, gases and odors are adsorbed from the air passing through the unit.

FEATURES

- Variety of filter combinations available; High Efficiency Particulate Air (HEPA) filter is 99.97% efficient and the hospital grade particle filter is 95% D.O.P. efficient at 0.3 micron particles. There is also a 95% ASHRAE filter.
- Circulates up to 2600 cfm.
- Designed to overcome the increase in air flow resistance normally caused by filter loading.
- Negative and positive pressure rooms can be created with air cleaner.
- CPZ™ module removes up to 95% of the space odors for up to 24 months.
- 3-Speed remote wall switch.
- 120 Vac, 60 Hz and 230 Vac, 50Hz models available.

• READ AND SAVE THESE INSTRUCTIONS

Contents

Application	1
Features	1
Specifications	2
Ordering Information	2
Planning the Installation	6
Installation	10
Operation.....	12
Service	13
Troubleshooting	14
Parts List.....	14
Limited Two-Year Warranty	16

SPECIFICATIONS

IMPORTANT

The specifications given in this publication do not include normal manufacturing tolerances. Therefore, this unit may not exactly match the listed specifications. Also, this product is tested and calibrated under closely controlled conditions, and some minor differences in performance can be expected if those conditions are changed.

Blower/Motor: Three speed direct drive forward curve.

Models / Electrical Ratings / Air Volume: Refer to Table 1. The F116 Series 2 air cleaner is available in two cabinet sizes. The shorter cabinet uses a prefilter with one primary filter while the longer cabinet (3 bay) uses a prefilter with two primary filters. Refer to Table 1 for models.

Accessories:

Remote 3-Speed Wall Switch

Approvals:

Underwriters Laboratories Inc.: cULus pending.

Starting Internal Static Pressure: See Table 2 .

Initial Internal Static Pressure / Installation Weight:

Approximately 108 lb to 229 lb (kg) depending on the filter configuration. Refer to Table 2.

Table 1. F116 Series 2 Filter Configuration and Air Volume.

Model*	Electrical Ratings	Filters (2 stage and 3 stage)		High cfm(m ³ /hr)	Medium cfm (m ³ /hr)	Low cfm (m ³ /hr)
		Bay 2	Bay 3			
F116A1021-3S	120 Vac, 60 Hz, 8.7A	99.97% HEPA	N/A	1975 (3355)	1825 (3100)	1500 (2550)
F116A1047-3S**	120 Vac, 60 Hz, 11.2A	95% at 0.3 micron	N/A	2450 (4160)	2150 (3650)	1575 (2675)
F116A1047-3S**	120 Vac, 60 Hz, 12.0A	95% ASHRAE	N/A	2600 (4425)	2125 (3600)	1575 (2675)
F116A1047-3S**	120 Vac, 60 Hz, 12.5A	CPZ™ modules	N/A	2575 (4375)	2075 (3525)	1475 (2500)
F116A1120-3S**	120 Vac, 60 Hz, 7.0A	99.97% HEPA	CPZ™ modules	1475 (2500)	1425 (2425)	1275 (2150)
F116A1120-3S**	120 Vac, 60 Hz, 7.5A	95% at 0.3 micron	CPZ™ modules	1775 (3000)	1700 (2875)	1500 (2550)
F116A1120-3S**	120 Vac, 60 Hz, 7.8A	95% ASHRAE	CPZ™ modules	1825 (3100)	1700 (2875)	1475 (2500)
F116A1120-3S**	120 Vac, 60 Hz, 7.5A	CPZ™ modules	CPZ™ modules	1675 (2850)	1600 (2700)	1400 (2375)
F116A2021-3S	230 Vac, 50 Hz, 3.2A	99.97% HEPA	N/A	1475 (2500)	1375 (2325)	1175 (2000)
F116A2048-3S**	230 Vac, 50 Hz, 3.7A	95% at 0.3 micron	N/A	2050 (3475)	1825 (3100)	1375 (2325)
F116A2048-3S**	230 Vac, 50 Hz, 4.0A	95% ASHRAE	N/A	2225 (2775)	1925 (3275)	1375 (2325)
F116A2048-3S**	230 Vac, 50 Hz, 3.5A	CPZ™ modules	N/A	1775 (3000)	1650 (2800)	1325 (2250)
F116A2121-3S**	230 Vac, 50 Hz, 3.0A	99.97% HEPA	CPZ™ modules	1175 (2000)	1100 (1875)	1000 (1700)
F116A2121-3S**	230 Vac, 50 Hz, 3.2A	95% at 0.3 micron	CPZ™ modules	1450 (2475)	1375 (2325)	1200 (2025)
F116A2121-3S**	230 Vac, 50 Hz, 3.2A	95% ASHRAE	CPZ™ modules	1525 (2600)	1425 (2425)	1225 (2075)
F116A2121-3S**	230 Vac, 50 Hz, 3.0A	CPZ™ modules	CPZ™ modules	1375 (2325)	1300 (2200)	1150 (1950)

*All Models come with 30% ASHRAE Prefilter in Bay 1.

**Filters purchased separately

ORDERING INFORMATION

If you have additional questions, need further information, or would like to comment on our products or services, please write or phone:

- Your local Honeywell Commercial Air Products Distributor.**
- Air-Pure Systems**
16873 Fish Point Rd. SE
Prior Lake, MN 55372
www.cleanairfacility.com
Phone: (800) 998-1919
Fax: (800) 221-3248

Table 2. F116 Series 2 Filter Configuration, Internal Static Pressure, and Hanging Weight with Filters.

Model**	Filters (2 stage and 3 stage)		Starting Internal Static Pressure (inches of Water Gauge)			Hanging Weight with Filters in lbs (kg)
	Bay 2	Bay 3	High	Medium	Low	
F116A1021-3S	99.97% HEPA	N/A	1.5"	1.4"	1.1"	149 (68)
F116A1047-3S*	95% at 0.3 micron	N/A	1.2"	1.0"	0.6"	130 (59)
F116A1047-3S*	95% ASHRAE	N/A	1.1"	0.8"	0.5"	108 (49)
F116A1047-3S*	CPZ™ modules	N/A	1.6"	1.3"	0.9"	143 (65)
F116A1120-3S*	99.97% HEPA	CPZ™ modules	1.7"	1.6"	1.4"	205 (93)
F116A1120-3S*	95% at 0.3 micron	CPZ™ modules	1.6"	1.5"	1.3"	193 (88)
F116A1120-3S*	95% ASHRAE	CPZ™ modules	1.6"	1.5"	1.2"	189 (86)
F116A1120-3S*	CPZ™ modules	CPZ™ modules	1.7"	1.6"	1.3"	229 (104)
F116A2021-3S	99.97% HEPA	N/A	1.1"	1.0"	0.8"	149 (68)
F116A2048-3S*	95% at 0.3 micron	N/A	1.0"	0.8"	0.5"	130 (59)
F116A2048-3S*	95% ASHRAE	N/A	0.9"	0.7"	0.4"	108 (49)
F116A2048-3S*	CPZ™ modules	N/A	1.1"	1.0"	0.6"	143 (65)
F116A2121-3S*	99.97% HEPA	CPZ™ modules	1.2"	1.1"	0.9"	205 (93)
F116A2121-3S*	95% at 0.3 micron	CPZ™ modules	1.1"	1.0"	0.8"	193 (88)
F116A2121-3S*	95% ASHRAE	CPZ™ modules	1.1"	1.0"	0.8"	189 (86)
F116A2121-3S*	CPZ™ modules	CPZ™ modules	1.2"	1.1"	0.9"	229 (104)

Filtration Efficiency:

See Table 3.

Replacement Parts See Parts List, Table 5.

Dimensions:

Refer to Figures 1 and 2 for dimensions

Table 3. F116 Series 2 Filter Description.

Filter	Dimensions in inches (mm)	Efficiency	Description
Prefilter	24 x 24 x 4 (610 x 610 x 102)	30% to 40%	Disposable pleated synthetic fiber in beverage board frame.
HEPA	24 x 24 x 12 (610 x 610 x 305)	99.97% at 0.3 micron at 2000 cfm (57 m3/min)	In metal frame with aluminum pleat separators in the media.
D.O.P.	24 x 24 x 12 (610 x 610 x 305)	95% at 0.3 micron at 2000 cfm (57 m3/min)	In metal frame.
ASHRAE	24 x 24 x 12 (610 x 610 x 305)	95% ASHRAE dust spot at 2000 cfm (57 m3/min)	In metal frame.
Sorbent Module Options: • Charcoal only • Permanganate only • Zeolite only or • CPZ material (combination of the above ingredients)	12 x 12 x 22 (305 x 305 x 559)	85% first pass at 1600 cfm for most gases / odors.	Disposable filter with at least twenty pounds of CPZ. Must use two modules per bay.

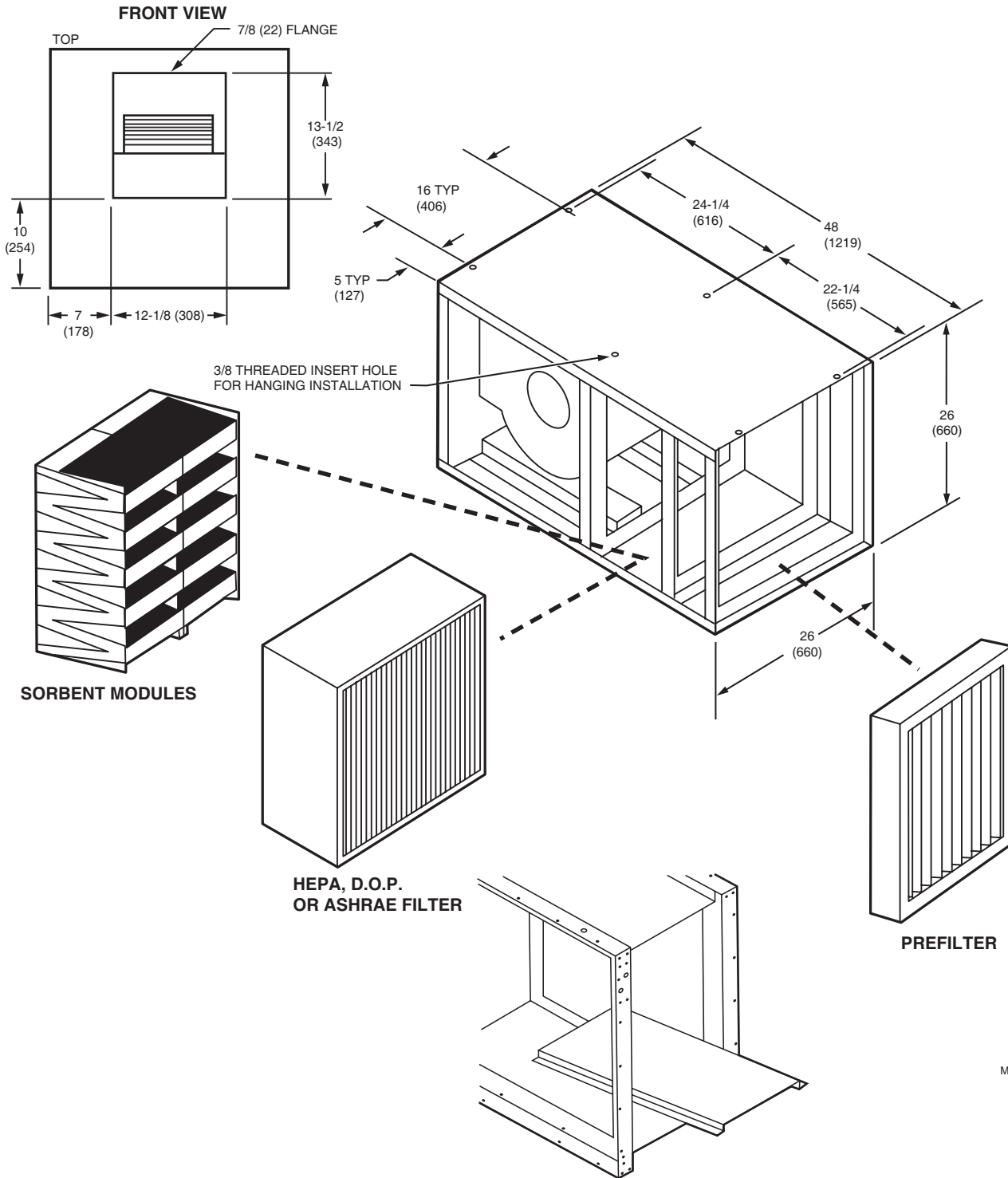

M10810B

ALL MODELS, EXCEPT F116A1021 AND F116A2021, ARE EQUIPPED WITH A DISPOSABLE ALUMINUM SPACER. THE SPACER IS SUPPLIED TO ACCOMMODATE THE CPZ MODULES. IF YOU DO NOT USE THE CPZ MODULES, REMOVE THE SPACER. IF YOU USE TWO SETS OF CPZ MODULES (4 MODULES) IN A THREE STAGE CABINET, YOU WILL REQUIRE AN ADDITIONAL SPACER. SAVE A FEW SPACERS THAT ARE NOT NEEDED TO ACCOMMODATE FUTURE NEEDS.

M7829D

Fig. 1. Approximate dimensions of F116 2-stage filtering model in inches (mm).

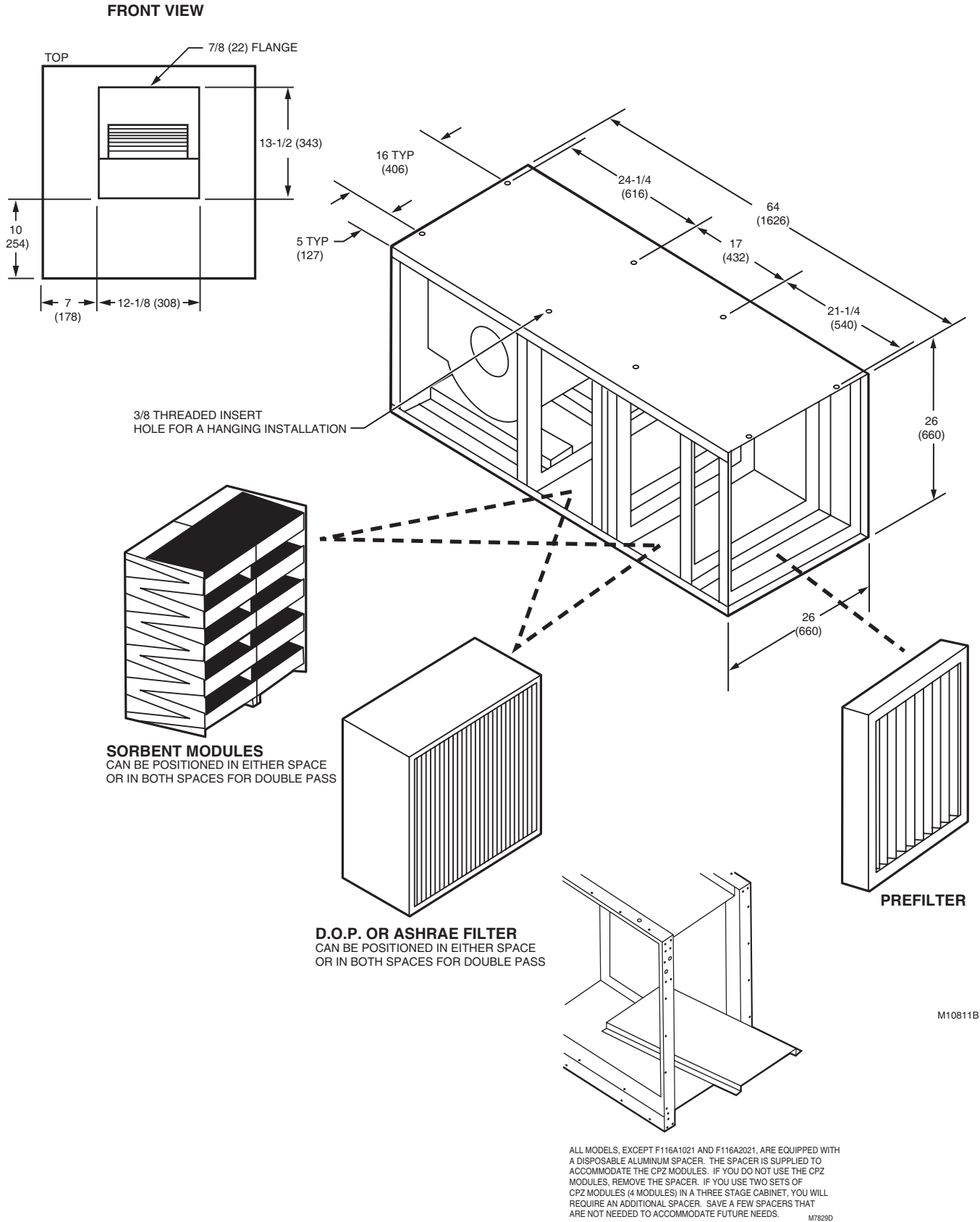

Fig. 2. Approximate dimensions of F116 3-stage filtering model in inches (mm).

PLANNING THE INSTALLATION

⚠ WARNING

TO REDUCE THE RISK OF FIRE, ELECTRICAL SHOCK, OR INJURY TO PERSONS, OBSERVE THE FOLLOWING:

1. Installation Work And Electrical Wiring Must Be Done By Qualified Person(s) In Accordance With All Applicable Codes And Standard, Including Fire Rated Constructions.
2. When Cutting Or Drilling Into The Wall Or Ceiling, Do Not Damage Electrical Wiring And Other Hidden Utilities.
3. Never Place A Switch Where It Can Be Reached From A Tub Or Shower.
4. Use This Unit Only In The Manner Intended By The Manufacturer. If You have Questions, Contact The Manufacturer.
5. Before Servicing Or Cleaning Unit, Switch Power Off At Service Panel And Lock Service Panel To Prevent Power From Being Switched on Accidentally.
6. If This Unit Is To Be Installed Over A Tub Or Shower, It Must Be Marked As appropriate For The Application and be connected to a GFCI (Ground Fault Circuit Interrupter) - protected branch circuit.

Static Pressure / Ducting

Smooth round duct offers the least resistance (static pressure) to airflow. Round ducting with a total inside area of 200 square inches (approximately 16" diameter) and a maximum straight run length of 100 feet, with approximately 2300 CFM passing through it, develops approximately 0.2" W.G. of static pressure.

A square or rectangular duct with 100 feet of straight length, 240 square inches of opening (approximately 15" x 16") with approximately 2300 CFM passing through it, develops 0.2" W.G. of static pressure.

Add 0.35" W.G. pressure for each 90° elbow in the system, and 0.05" W.G. for each change in duct diameter, slight bend, and grill / diffuser used. Use a duct system whose face area is equal to those mentioned. Increase the duct face area to reduce pressure, decrease the duct face to increase pressure.

Use of flexible ducting, corrugated ducting and duct board will add approximately 15% to 30% additional static pressure compared with smooth surface metal ducts (galvanized or painted sheet metal) of equal size.

To compute round duct face area in square inches, multiply the square of the diameter in inches by 0.7854. Multiply the width in inches by the height in inches of a rectangular or square duct to find its face area in square inches.

If there is too much ducting pressure, the net air volume will reduce from the system, thus stressing the motor and potentially causing motor damage.

Consult with a mechanical engineer or contractor experienced in duct design and pressure calculations for assistance in ducting your F116 Series 2 air cleaner.

Choose Location

Choosing a location that is readily accessible for regular inspection and cleaning. Allow enough room for removing the prefilter and primary filters. Be sure there is room for servicing without removing pipes, ducts, or other heating system components. See Fig. 3 through 11 for suggested locations.

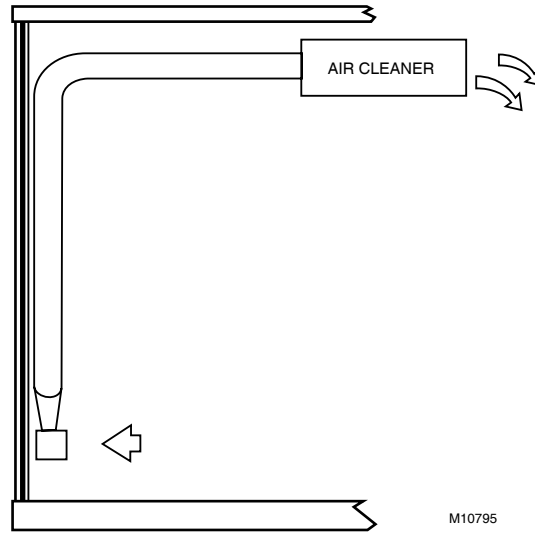

Fig. 3. Positioning air cleaner for vapor control in printing, brazing, soldering, or glue shops.

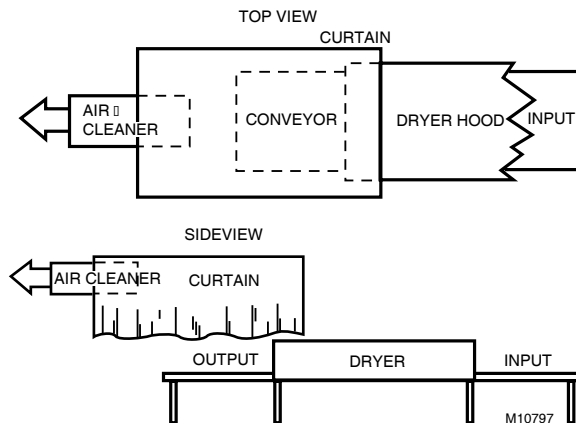
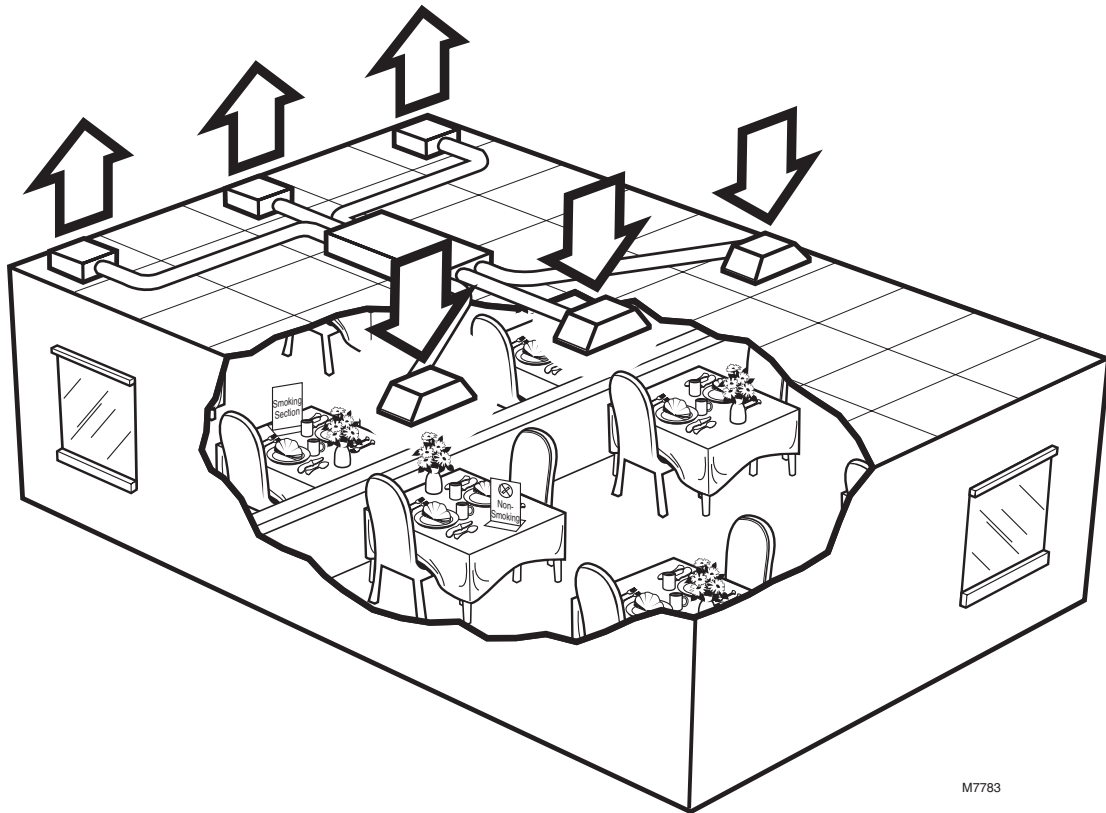
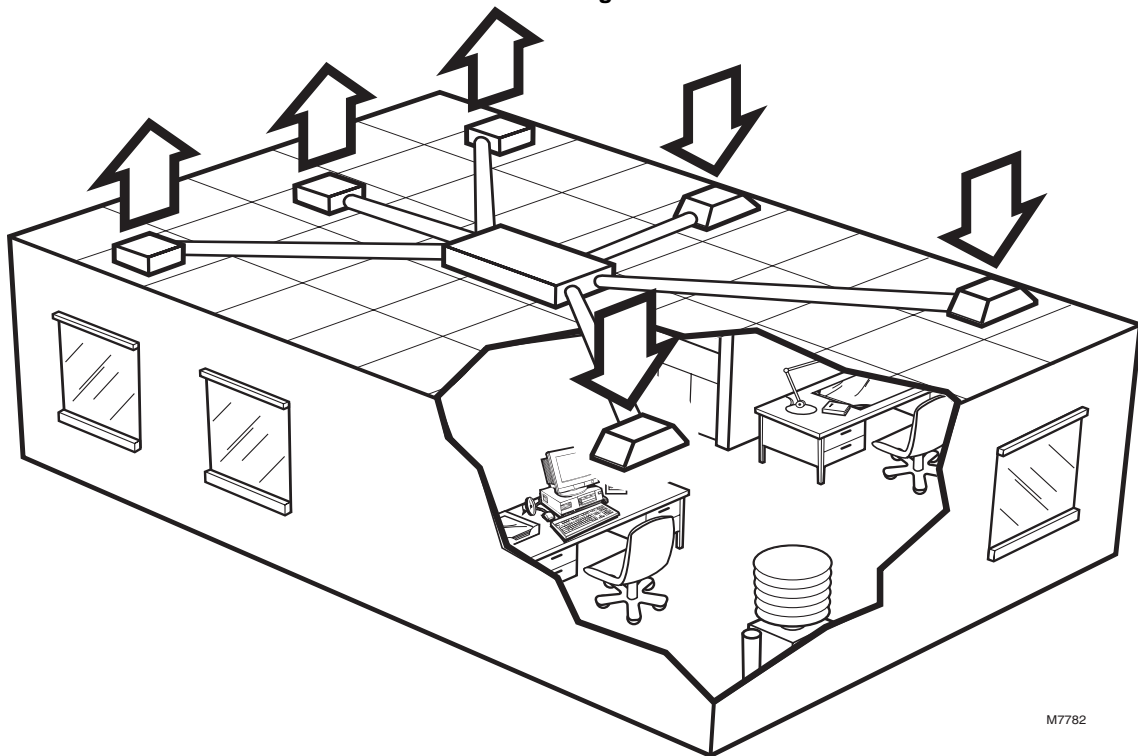

Fig. 4. Positioning air cleaner to remove pollutants from a conveyor feed process such as screen printing.



M7783

Fig. 5. Positioning air cleaners at the far end of the restaurant smoking section to draw the smoke away from the nonsmoking section.



M7782

Fig. 6. Positioning air cleaners to create a negative pressure in polluted spaces and creating a positive pressure in nonpolluted areas. Use this positioning in in-plant offices and hospitals.

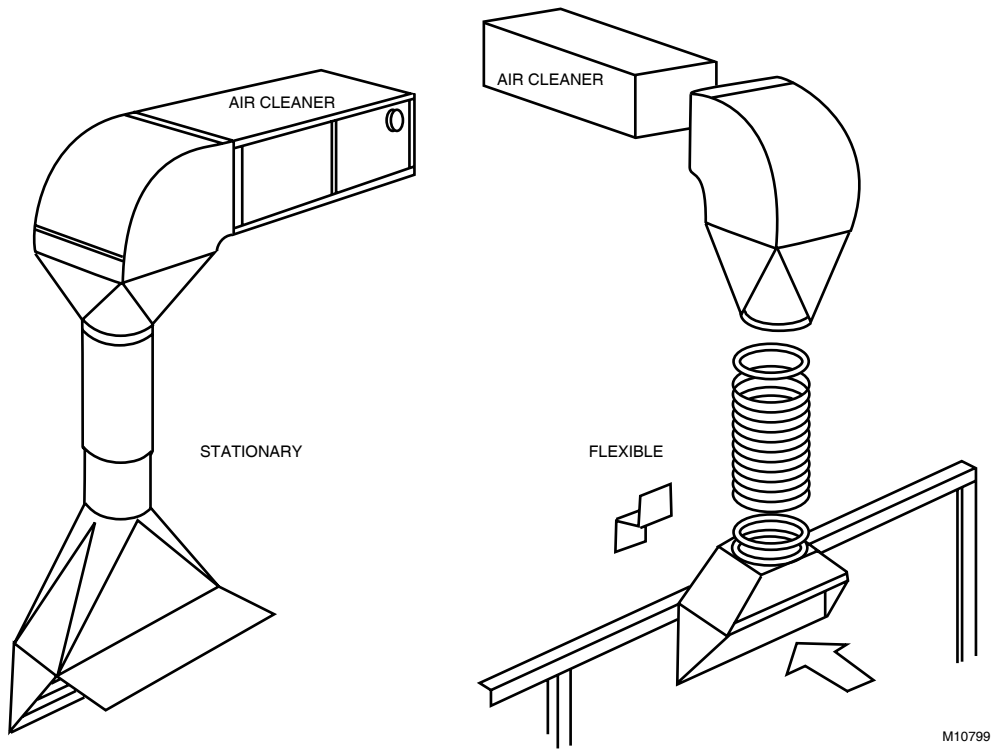

Fig. 7. Positioning air cleaner for suspended side draft applications.

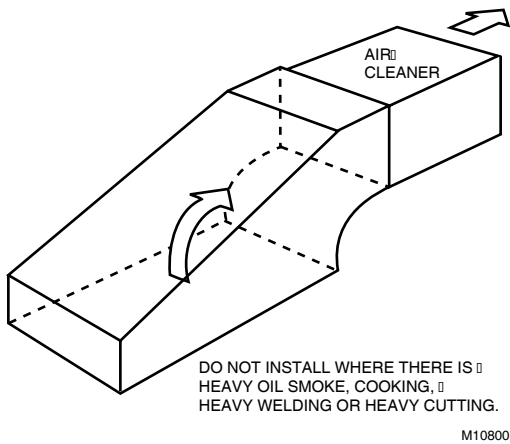

Fig. 8. Connecting air cleaner directly to a canopy hood with a minimum air entrance velocity of 120 fpm.

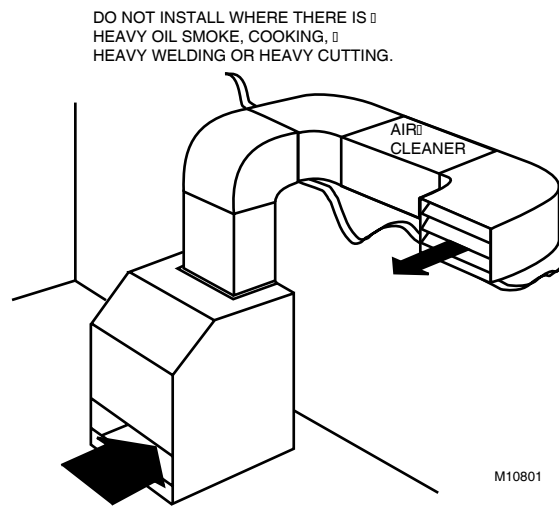

Fig. 9. Positioning air cleaner to recirculate existing exhaust system air which contains light to medium quantities of pollutants.

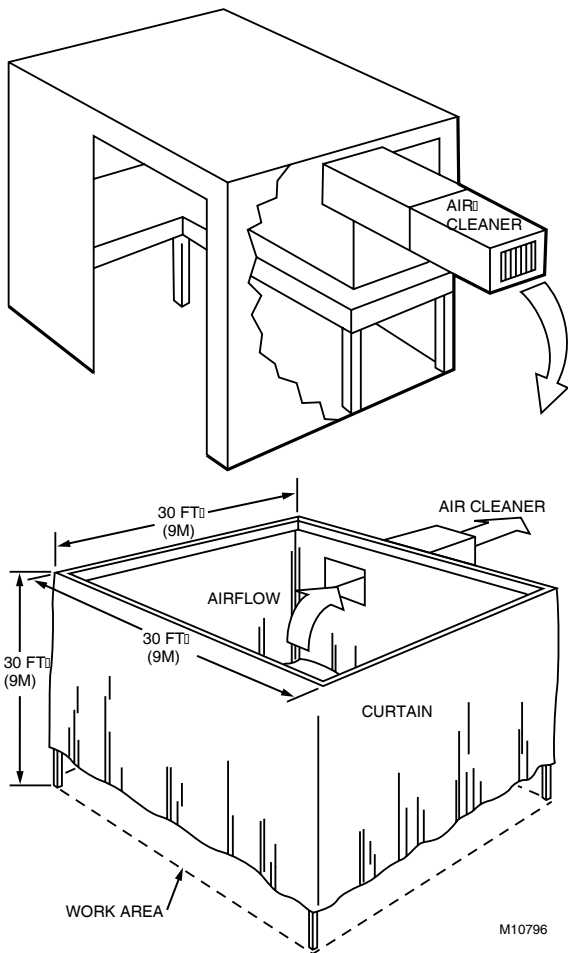

Fig. 10. Positioning air cleaner to create a negative pressure booth that contains a contamination generating process.

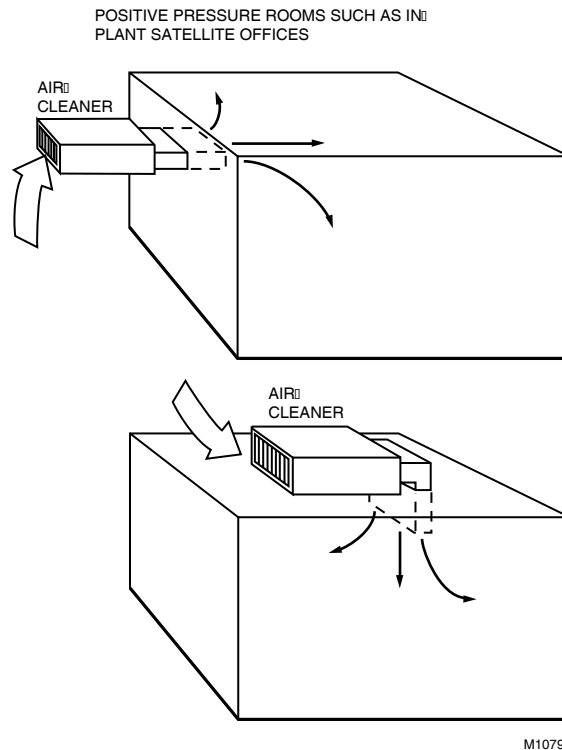

Fig. 11. Positioning air cleaner to create positive pressure for plant satellite office.

INSTALLATION

⚠ WARNING

Explosion Hazard Possible.
Can cause personal injury or equipment damage.
 Do not install or use the F116 Series 2 air cleaner where there is any danger of gas, vapor or dust explosion.

IMPORTANT

This air cleaner has not been investigated for use in the ceilings of fire-resistant assemblies.

⚠ CAUTION

Electrical Hazard.
Can cause personal injury or equipment damage.
 Turn off power before installing or servicing the air cleaner.

IMPORTANT

Stand on a stable platform when working with the air cleaner.

When Installing this Product...

1. Read these instructions carefully. Failure to follow them could damage the product or cause a hazardous condition.
2. Check the ratings given in the instructions and on the product to make sure the product is suitable for your application.
3. Installer must be a trained, experienced service technician.
4. After installation is complete, check out product operation as provided in these instructions.

⚠ WARNING

Remove packing materials / Parts from inside the Motor / Blower compartment prior to installation or initial power on.

Mount Air Cleaner Cabinet

The F116 Series 2 air cleaner must be attached to a structure capable of supporting the weight of the unit with filters, ducting and plenums when used. Roof trusses, bar joists and floor joists are examples of suitable structures.

IMPORTANT

All suspension points (either six or eight depending on the model) must be used for proper and safe installation. See Fig. 1 and 2 for dimensions between the suspension points.

Threaded rod, eyebolts with chains, or any standard practice and hardware for hanging method can be used in the suspension of the air cleaner. See Fig. 12.

NOTE: State and local codes and accepted installation practices must be followed.

**FASTEN SECURELY TO STRUCTURAL SUPPORT SYSTEM
 I.E. BAR JOIST, CONCRETE SLAB, TIMBER FRAMING, ETC.**

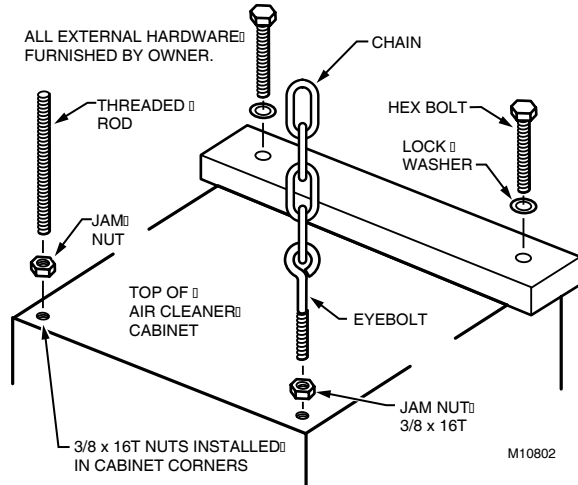

Fig. 12. Fastening air cleaner to a structural support system (bar joist, concrete slab, or timber framing).

Installation with Ducting

Use a transition or box plenum to attach the ducting to the air cleaner inlet and outlet. On the inlet, a transition plenum is preferred, see Fig. 13.

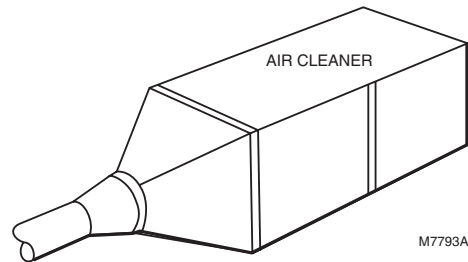

Fig. 13. Transition plenum connected to the air cleaner inlet.

If a box plenum is used on the inlet, a diffusion screen must be installed in the box, see Fig. 14. A box plenum can accommodate more than one inlet

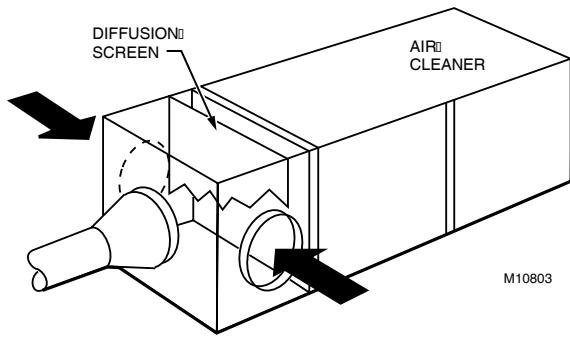

Fig. 14. Box plenum with diffusion screen and three inlets connected to the air cleaner inlet.

On the outlet, use a square-to-round or square-to-square connection when attaching the air cleaner outlet to the blower discharge flange, see Fig. 15. The outlet connection can be used with a Y-branch, distribution box or manifold as required.

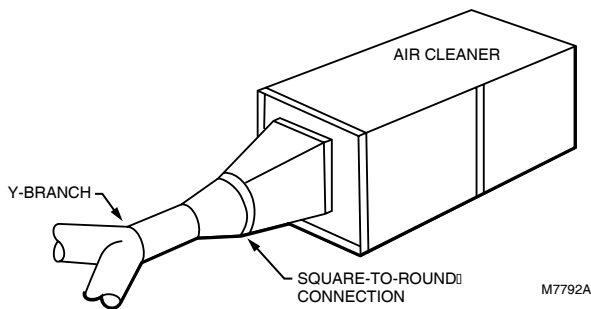

Fig. 15. Square-to-round connection attached to the air cleaner outlet.

Electrical Hookup

All wiring must comply with applicable codes and ordinances. The power source must agree with the model type: 120V, 60 Hz or 230V, 50 Hz. Refer to figure 16 for electrical connection setup.

1. Remove screws on motor compartment cover and remove.
2. Refer to figure 16 for typical electrical diagram

⚠ WARNING

Risk of Fire or Electric Shock.

Can cause personal injury or equipment damage.

Use only Honeywell 190097C Remote Speed Switch (3-speed models only) to regulate air cleaner speed. Using a different speed switch may void the warranty.

IMPORTANT

- Be sure the air cleaner is grounded for correct operation and safety.
- Canadian installation: NEVER install in ceilings with thermal insulation value greater than R-40.

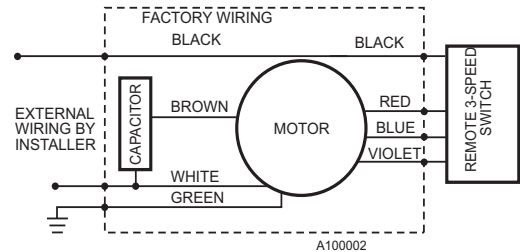

Fig. 16. Typical F116 Series 2 only 120V, 60 Hz or 230V, 50 Hz wiring diagram.

Remote 3 Speed Wall Switch (F116 Series 2)

The 190097C Remote Wall Switch Assembly allows control of the F111 model air cleaners from a location separate from the air cleaner. The assembly includes a remote switch with an outlet box cover, outlet box, extension ring, and a wire harness. Wiring to connect the remote switch and air cleaner must be furnished separately.

⚠ CAUTION

- This installation to be performed only by a qualified installer.
- All wiring to comply with local electrical codes.
- Disconnect power to air cleaner at fuse or breaker before beginning work. Failure to do so can result in shock hazard endangering equipment and personal safety of installer.
- Only one air cleaner can be connected to a remote switch

1. Disconnect power to air cleaner.
2. Mount 4" x 4" outlet box at desired remote location.
3. Attach 3/4" extension ring to outlet box.
4. Run five conductor, color-coded, 14-gauge wires from the remote switch location to the air cleaner.
5. Use three wire nuts to connect three color-coded, lead wires on the remote switch to three color-coded wires from the air cleaner. (Red, Blue, Violet)
6. Use one wire nut to connect white color-coded, lead wire from the air cleaner to single color-coded wire from the power supply. (White)

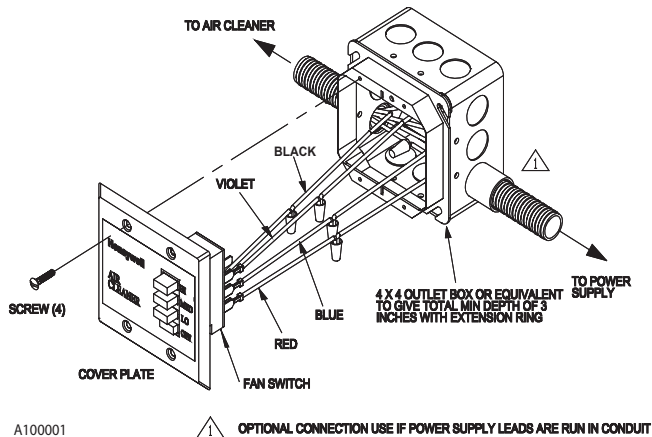

Fig. 17. Wiring 3-Speed Remote Switch

7. Connect the ground wire from the power supply to a ground stud of the outlet box.(Green)
8. Connect the ground wire from the air cleaner to the ground stud of the outlet box.(Green)
9. Use one wire nut to connect the black color-coded, lead wire on the remote switch to the black color-coded wire from the power supply.
10. Fold wires into box and mount remote switch on outlet box. Leave switch in OFF position.
11. On the air cleaner remove two screws on wiring compartment cover and open
12. Run five conductor, color coded, 14 gauge wires from the remote switch through the air cleaner access opening into the wiring compartment. Strip ends of remote switch lead wires
13. Connect three wires on air cleaner to remote switch lead wires with wire nuts following color code used at remote switch. (Red, Blue, Violet)
14. Connect one wire on air cleaner to power supply wire with a wire nut following color code used at remote switch. (White)
15. Connect the ground wire from the remote switch to a ground stud of the wiring compartment cover.(Green)
16. Fold wires into wiring compartment. Replace wiring compartment cover.
17. Turn on power to air cleaner at fuse or breaker.
18. Check operation by turning air cleaner at HIGH, MEDIUM, and LOW. **Note** that only the remote switch will operate the air cleaner.
19. Turn off the power and install the filters in the cabinet.

NOTE: Select models have a disposable aluminum spacer. the spacer is necessary only when using the CPZ modules. All other filters need to remove and save the spacer for future needs. Refer to figures 1 and 2.

20. Replace the motor compartment cover.

OPERATION

Because the F116 Series 2 air cleaner provides its own circulation, it can be mounted independently or in a duct system. When used in a duct, the air cleaner volume must be the same as the duct and plenum.

When the air cleaner is powered, the blower/motor draws the contaminated air into the air cleaner. Particles that are too small to be caught in the prefilter are trapped by the primary filter. The clean air is then discharged (two stage) or goes through a second primary filter (three stage) and is then discharged.

The F116 Series 2 air cleaner has been engineered to improve indoor air quality for commercial and industrial applications. The filters are the most practical and effective filtering system for removing atmospheric dust, pollens, bacteria, viruses, mold spores, smoke, fumes, mists and aerosols. Refer to Fig. 8.

The air cleaner is either operating or off. There are no other operational options available. Even when the area is unoccupied, the air cleaner can be operated continuously to prevent buildup of airborne contaminants. Operate the air cleaner only when the area is occupied when specific activities produce contaminants.

The CPZ™ sorbent module has the ability to collect and hold gas-phase compounds and vapors typically found in commercial and light industrial facilities. These gases and vapors frequently appear as odors that, at times, can be annoying and irritating. The modules become saturated after collecting 25% to 50% of their weight in gaseous odors. The quantity of CPZ™ material provides adequate dwell time to ensure up to 95% collection efficiency in the first pass. This also provides a long maintenance-free service life.

The minimum recommended air exchange rate is 2.5 times per hour. In a heavily contaminated area, up to 15 air exchanges per hour can be necessary. The factors that determine what the rate of air exchange should be are:

- generation rates of the various pollutants;
- concentration level of the pollutants;
- desired contamination reduction level.

Airborne contaminants will always be present in the air where contaminant generations take place. Air cleaning systems and ventilators do not eliminate airborne contaminants, they reduce the excessive accumulation of the contaminants. To eliminate the contamination, the source of contamination must be removed.

Local, Federal and professional ventilation engineering standards and codes prescribe minimum ventilation rates to dilute air contamination in specific applications. The ventilation rates usually assume the injection of outdoor air measured as air exchange rate. The use of the F116 air cleaner to comply with ventilation requirements is an acceptable alternative to ventilation with outdoor air. However, at least 20% of a specified ventilation rate or code must be derived from outdoor air. The F116 air cleaner filtered and recirculated air can be the remaining 80%.

SERVICE



CAUTION

Electrical Hazard.

Can cause personal injury or equipment damage.

Turn off power before installing or servicing the air cleaner.

IMPORTANT

Be sure to change filters as recommended to prevent reduced airflow in the air cleaner. Stand on a stable platform when working with the air cleaner.

IMPORTANT

Air cleaner and components are susceptible to damage. Take care when working with them to avoid equipment damage.

The air cleaner removes a variety of particulate contaminants from the air. In the process of cleaning the air, the air cleaner filters become dirty and the cleaning efficiency is lowered.

To maintain a high standard of reliability and efficiency, it is necessary to periodically service the air cleaner. The maintenance is determined by the quantity and type of contaminants present and the frequency of air cleaner use. The frequency of servicing can be established after a period of use.

NOTE: Some full-service distributors provide regular servicing to commercial establishments.

The particle filter life ranges from 6 to 24 months with 12 to 18 months as an average. The useful life of the CPZ™ sorbent modules may vary from 4 to 24 months, depending on the application. In most applications, the sorbent media life ranges from 4 to 12 months. The filters and modules need to be changed more frequently in facilities that operate 24 hours a day.

Determining Media Filter Change

Media type particulate filters cause an increase in pressure as they collect and retain airborne particulates. The best way to determine when to replace these filters involves monitoring the pressure across the filters with a differential pressure gauge.

If a differential pressure gauge is not used, the apparent air volume that one feels is a good indicator of the filter loading. When the air volume is noticeably less, the cleanliness of the air in the space will decline. When that occurs, change the primary media filter(s). Then schedule the next primary media filter(s) change to occur 60 days earlier than the first filter change. Typically, change the prefilter at least every 3 months and the primary media filter(s) 12 to 18 months.

CPZ™ Adsorbent Module

The CPZ™ adsorbent module is used to collect gases, vapors, odors and volatile organic compounds (V.O.C.) from the air that passes through the air cleaner. Adsorbents collect and hold 25% to 50% of their weight in odorous gases and vapors. The impurities are collected until the adsorbents reach saturation. At saturation, the adsorbents emit a continuous strong pungent odor. If the air cleaner is turned off for 8 to 10 hours, there will be a temporary odor when it is turned back on. If the odor persists for 30 minutes, it is time to replace the filters.

Prefilter, Media Filters and CPZ Modules

The disposable prefilter collects large dust particulates and lint-type airborne fibers. Check the filter every 3 months to determine the replacement frequency:

IMPORTANT

Do not touch the pleated filter media. Handle only the filter frame to prevent damage to the filter media.

1. Verify power shut off
2. Remove the air cleaner cover and set aside.
3. Remove the prefilter and primary filters.
4. Check the prefilter and replace if it is fully coated with dust and lint. (approximately every 3 months)
5. Replace the primary media filter(s) when there is a noticeable loss of air volume from the air cleaner (approximately every 12 - 18 months)
6. Replace the CPZ sorbent modules when a continuous noticeable odor is emitted from the air cleaner. (approximately every 4 to 12 months).
7. Reassemble the air cleaner and turn the power on.

On initial startup, a small amount of dust can blow from the air cleaner. This is normal and stops a few minutes after startup. After running the unit for 5 minutes, turn off the unit, the unit is ready for operation.

TROUBLESHOOTING



CAUTION

Electrical Hazard.

Can cause personal injury or equipment damage.

The following procedures expose hazardous live parts. Disconnect power before installing or servicing the air cleaner.

Table 4. Troubleshooting the F116 Series 2 Air Cleaner

Model*	Electrical Ratings
Motor will not start	<ul style="list-style-type: none"> • Check wiring for loose connections - Tighten if necessary. • Check capacitor - Replace if necessary. • Check for hot motor - Thermal protection relay is tripped, reset it. • Replace motor.
Vibration - High Frequency	<ul style="list-style-type: none"> • Check that blower wheel is balanced - remove and balance or replace wheel.
Vibration - Low Frequency	<ul style="list-style-type: none"> • Check if system is operating above 2.0" W.G. pressure - reduce total pressure by replacing filters.
Scraping noise	<ul style="list-style-type: none"> • Check if the blower wheel is touching the blower housing - adjust blower and position wheel in the center of the inlet ring.
Squeal or whistle noise	<ul style="list-style-type: none"> • Check for air leaks in the cabinet doors or ducting - plug air leaks.

PARTS LIST

Refer to Fig. 18 and Table 5 for replacement part information

Table 5. Replacement Parts.

Fig. Reference No.	Description	Pack Qty	Order Number	Reference No.
1	Prefilter	1 box of 6	32000200	860039
2	99.97% HEPA media filter	1	32000198	860023
	95% D.O.P hospital grade filter	1	32000195	860024
	95% ASHRAE particle filter	1	32000196	860025
	CPZ™ sorbent module (requires 2)	1	32004078-001	N/A
	Charcoal sorbent module (requires 2)	1	32004078-002	N/A
	Zeolite sorbent module (requires 2)	1	32004078-003	N/A
	Permanganate sorbent module (requires 2)	1	32004078-004	N/A
OPTIONAL Parts not shown in Fig. 9.				
	Remote Wall 3-Speed Switch, Series 3	1	190097C	
	Capacitor, Series 2	1	32000551-001	
	Motor / Blower; 120 V, 60 Hz, Series 2	1	32000552-003	
	Motor / Blower; 230V, 50 Hz, Series 2	1	32000552-004	
	Motor; Three Speed 120 VAC, 60Hz, Series 2	1	32000553-003	
	Motor; Three Speed 230 VAC, 50Hz, Series 2	1	32000553-004	

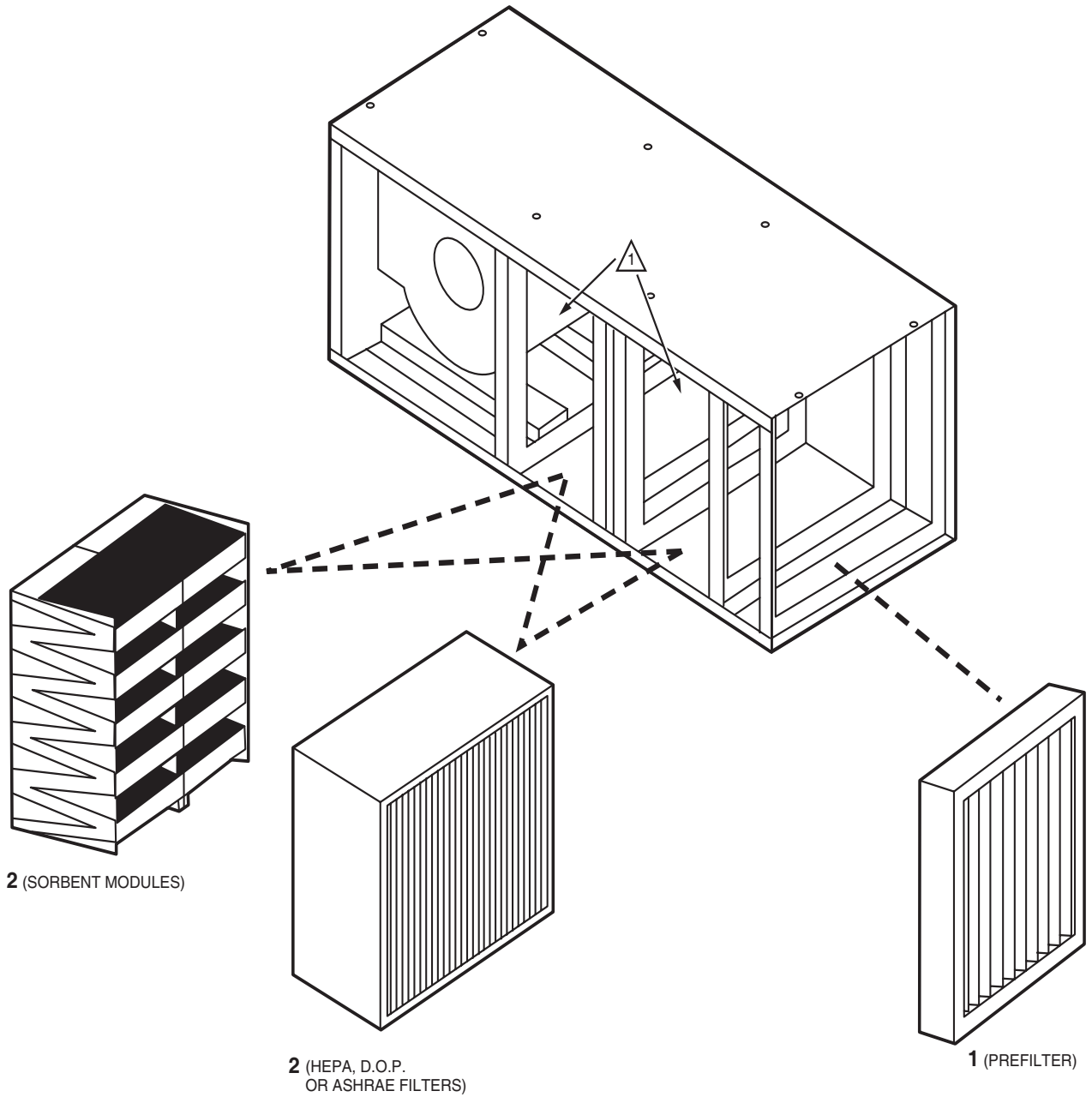

1 TWO STAGE MODELS WILL HAVE ONLY ONE PRIMARY FILTER AREA.

M10812B

Fig. 18. Exploded view of F116 Series Air Cleaner components.

LIMITED TWO-YEAR WARRANTY

Air-Pure Systems warrants its air cleaner products to be free from defects in workmanship or materials under normal use and service, for a period of two (2) years from the date of purchase by the original end-user. If at anytime during the warranty period the product is defective or malfunctions, Air-Pure Systems, through the distributor or dealer, from which the product was purchased, or through an authorized warranty repair station, shall at Air-Pure Systems option, replace or repair the defective product or component.

This warranty does not cover removal or installation costs. This warranty shall not apply if it is shown that the defect or malfunction was caused by damage which occurred during handling or shipment, improper electrical connections, improper use of the product or abuse.

Air-Pure Systems sole responsibility shall be to repair or replace the product within the terms stated above. **AIR-PURE SYSTEMS SHALL NOT BE LIABLE FOR ANY LOSS OR DAMAGE OF ANY KIND, INCLUDING ANY INCIDENTAL OR CONSEQUENTIAL DAMAGES RESULTING, DIRECTLY OR INDIRECTLY, FROM ANY BREACH OF WARRANTY, EXPRESS OR IMPLIED, OR ANY OTHER FAILURE OF THIS PRODUCT.** (Some states do not allow the exclusion or limitation of incidental or consequential damages, so this limitation may not apply to you.) **THE WARRANTIES SET FORTH HEREIN ARE EXCLUSIVE AND AIR-PURE SYSTEMS EXPRESSLY DISCLAIMS ALL OTHER WARRANTIES, WHETHER WRITTEN OR ORAL, IMPLIED OR STATUTORY, INCLUDING BUT NOT LIMITED TO ANY WARRANTIES OF MERCHANTABILITY, WORKMANSHIP, OR FITNESS FOR A PARTICULAR USE.**

This warranty gives you specific legal rights and you may have other rights which vary from state to state.

How to make a warranty claim or have questions answered:

Should you have a warranty claim or questions about the warranty policy, contact the distributor or dealer from which you purchased the product or the authorized warranty repair stations nearest your location.

NOTE: Do not return any products or parts to the factory without a factory issued "Returned Warranty Goods Label" issued by Air Pure Systems.

In the event you or other persons, have any questions concerning the use and care of this product or this warranty please call or write the factory.

Air-Pure Systems
16873 Fish Point Rd. SE
Prior Lake, MN 55372-1714
Phone: (800) 998-1919
Fax: (800) 221-3248

Honeywell

Air-Pure Systems
16873 Fish Point Rd. SE
Prior Lake, MN 55372-1714
Phone (800) 998-1919
Fax: (800) 221-3248