

F116 (Series 16000) Self-Contained Ductable Commercial Air Cleaner

PRODUCT DATA



FEATURES

- Variety of filter configurations available to customize the air cleaner for any application.
- Three-speed direct drive forward curve blower/motor circulates up to 2500 cfm (72 m³/min) for large areas.
- Negative and positive pressure rooms can be created with the air cleaner.
- Charcoal, permanganate and zeolite (CPZ™) disposable modules can be used for odor control.
- Two stage and three stage air cleaners are compatible with a wide range of applications.
- 120 Vac, 60 Hz and 208-220 Vac, 50/60 Hz models available.

• READ AND SAVE THESE INSTRUCTIONS

APPLICATION

The F116 (Series 16) Self-Contained Ductable Commercial Air Cleaner uses direct drive forward curve blower/motor with a variety of filter configurations to remove airborne contaminants. The air cleaner provides its own air circulation, so it can be used in any situation that requires the removal of contamination from an enclosed area. The air going to the unit and the discharged air may be transported by a network of ducting and plenums or the unit can be used independently.

Contents

Application	1
Features	1
Specifications	2
Ordering Information	2
Planning the Installation	6
Installation	7
Service	12
Troubleshooting	13
Parts List	14
Warranty	16

The Honeywell Trademark is used under license from Honeywell Intellectual Properties, Inc. by Air-Pure Systems. Honeywell International Inc. makes no representations or warranties with respect to this product

F116 (SERIES 16000) SELF-CONTAINED DUCTABLE COMMERCIAL AIR CLEANER

SPECIFICATIONS

IMPORTANT

The specifications given in this publication do not include normal manufacturing tolerances. Therefore, this unit may not exactly match the listed specifications. This product is tested and calibrated under closely controlled conditions, and some minor differences in performance can be expected if those conditions are changed.

Models:

The F116 (Series 16000) air cleaner is available in two cabinet sizes. The shorter cabinet uses a prefilter with one primary filter while the longer cabinet uses a prefilter with two primary filters. Refer to Table 1 for model descriptions.

Construction:

.0508 in., 16 GA unpainted aluminum

Blower/Motor:

- three speed direct drive forward curve
- 1070 RPM nominal speed
- thermal circuit breaker

NOTE: Oil annually.

Static Pressure:

Minimum: 1.2" W.G.
Maximum: 1.85" W.G.

Electrical Ratings:

Running Load (all three fan speeds): must not exceed 14A at 120V or 7A at 220V.
Refer to Table 2 for maximum starting loads.

Table 1. F116 (Series 16000) Description.

Model	Voltage	Filtering Stages	Contains	Suggested Applications
F116A1021	120 Vac, 60 Hz, 1PHS, 14A	Two	1 prefilter and 1 HEPA filter	Medical isolation wards, industrial clean rooms, and source capture of highly toxic particulates
F116A1047	120 Vac, 60 Hz, 1PHS, 14A	Two	1 prefilter ^a	Any airborne particulate or gas/odor/VOC, but not in combination
F116A1120	120 Vac, 60 Hz, 1PHS, 14A	Three	1 prefilter ^a	Any particulate and/or gas/odor/VOC
F116A1122	220 Vac, 50/60 Hz, 1 PHS, 7A	Two	1 prefilter and 1 HEPA filter	Medical isolation wards, industrial clean rooms, source capture of highly toxic particulates
F116A2021S	220 Vac, 50/60 Hz, 1 PHS, 7A	Three	1 prefilter and 1 HEPA filter	Medical isolation wards, industrial clean rooms, source capture of highly toxic particulates
F116A2121	220 Vac, 50/60 Hz, 1 PHS, 7A	Three	1 prefilter ^a	Any respirable particulate and gas/odor/VOC application
F116A2048	220 Vac, 50/60 Hz, 1 PHS, 7A	Two	1 prefilter ^a	Any respirable particulate and gas/odor/VOC application

^a Primary filters must be ordered separately. The choices include a 95% D.O.P. filter, 95% or 65% ASHRAE dust spot filter or two sorbent media modules (CPZ).

ORDERING INFORMATION

If you have additional questions, need further information, or would like to comment on our products or services, please write or phone:

1. **Your local Honeywell Commercial Air Products Distributor.**
2. **Air-Pure Systems**
16873 Fish Point Rd. SE
Prior Lake, MN 55372-1714
Phone: (800) 998-1919
Fax: (800) 221-3248

F116 (SERIES 16000) SELF-CONTAINED DUCTABLE COMMERCIAL AIR CLEANER

Table 2. F116 (Series 16000) Maximum Starting Loads.

Fan Setting	Voltage	Amperes
HIGH	120V	23A
MEDIUM	120V	15A
LOW	120V	15A

Power:
Hardwire

Approvals:
UL and cUL pending.

Dimensions:
See Fig. 1 and 2 for dimensions.

Replacement Parts and Accessories:
See Parts List on page 14.

Air Volume, Internal Static Pressure and Installation Weight:

Air volume, internal static pressure and installation weight are based on the air cleaner filter configuration. Refer to Table 3.

Filtration Efficiency:
See Table 4.

Table 3. F116 (Series 16000) Filter Configuration, Recommended Air Volume, Internal Static Pressure and Hanging Weight with Filters.

Model Numbers	Filter Configuration	Recommended Air Volume in cfm (m ³ /min)	Approximate Internal Static Pressure at Recommended Air Volume	Hanging Weight with Filters in lbs (kg)
F116A1021 (16002) F116A1122 F116A2021S	HEPA filter (99.997%)	1600 (49)	1.3" W.G.	149 (68)
F116A1047 (16004) F116A2048	D.O.P. filter (95%)	1800 (52)	1.1" W.G.	130 (59)
	ASHRAE dust spot filter (95%)	2000 (58)	1.0" W.G.	108 (49)
	ASHRAE dust spot filter (65%)	2000 (58)	0.75" W.G.	108 (49)
	CPZ sorbent modules	1600 (49)	0.5" W.G.	143 (65)
F116A1120 (16012) F116A2121	D.O.P. filter and CPZ sorbent modules	1600 (49)	1.3" W.G.	198 (90)
	ASHRAE dust spot filter (95%) with CPZ sorbent modules	1600 (49)	1.0" W.G.	175 (79)
	ASHRAE dust spot filter (65%) with CPZ sorbent modules	1600 (49)	0.8" W.G.	175 (79)
	Two sets of CPZ sorbent modules	1600 (49)	0.8" W.G.	211 (96)
	ASHRAE dust spot filter (65%) with D.O.P. filter	1800 (52)	1.5" W.G.	162 (74)
	Two ASHRAE dust spot filters	2000 (58)	1.6" W.G.	139 (63)
	ASHRAE dust spot filter (95%) with D.O.P. filter	Not recommended		

F116 (SERIES 16000) SELF-CONTAINED DUCTABLE COMMERCIAL AIR CLEANER

Table 4. F116 (Series 16000) Filter Description.

Filter	Dimensions in inches (mm)	Efficiency	Comments
Prefilter	24 x 24 x 4 (610 x 610 x 102)	30% to 40%	Disposable pleated synthetic fiber in beverage board frame.
HEPA	24 x 24 x 12 (610 x 610 x 305)	99.97% at 0.3 micron at 1600 cfm (49 m ³ /min)	In metal frame with aluminum pleat separators in the media.
D.O.P.	24 x 24 x 12 (610 x 610 x 305)	95% at 0.3 micron at 1800 cfm (52 m ³ /min)	In metal frame.
ASHRAE dust spot	24 x 24 x 12 (610 x 610 x 305)	95% ASHRAE dust spot at 2000 cfm (58 m ³ /min)	In metal frame.
	24 x 24 x 12 (610 x 610 x 305)	65% ASHRAE dust spot at 2000 cfm (58 m ³ /min)	In metal frame.
Sorbent Module- Contents: - Charcoal only, - Permanganate only, - Zeolite only or - CPZ material (combination of the above ingredients)	11 1/2 x 11 1/2 x 23 (292 x 292 x 584)	85% first pass at 1600 cfm (49 m ³ /min) for most gases/odors	Twenty pounds of disposable CPZ modules. Must use two modules.

F116 (SERIES 16000) SELF-CONTAINED DUCTABLE COMMERCIAL AIR CLEANER

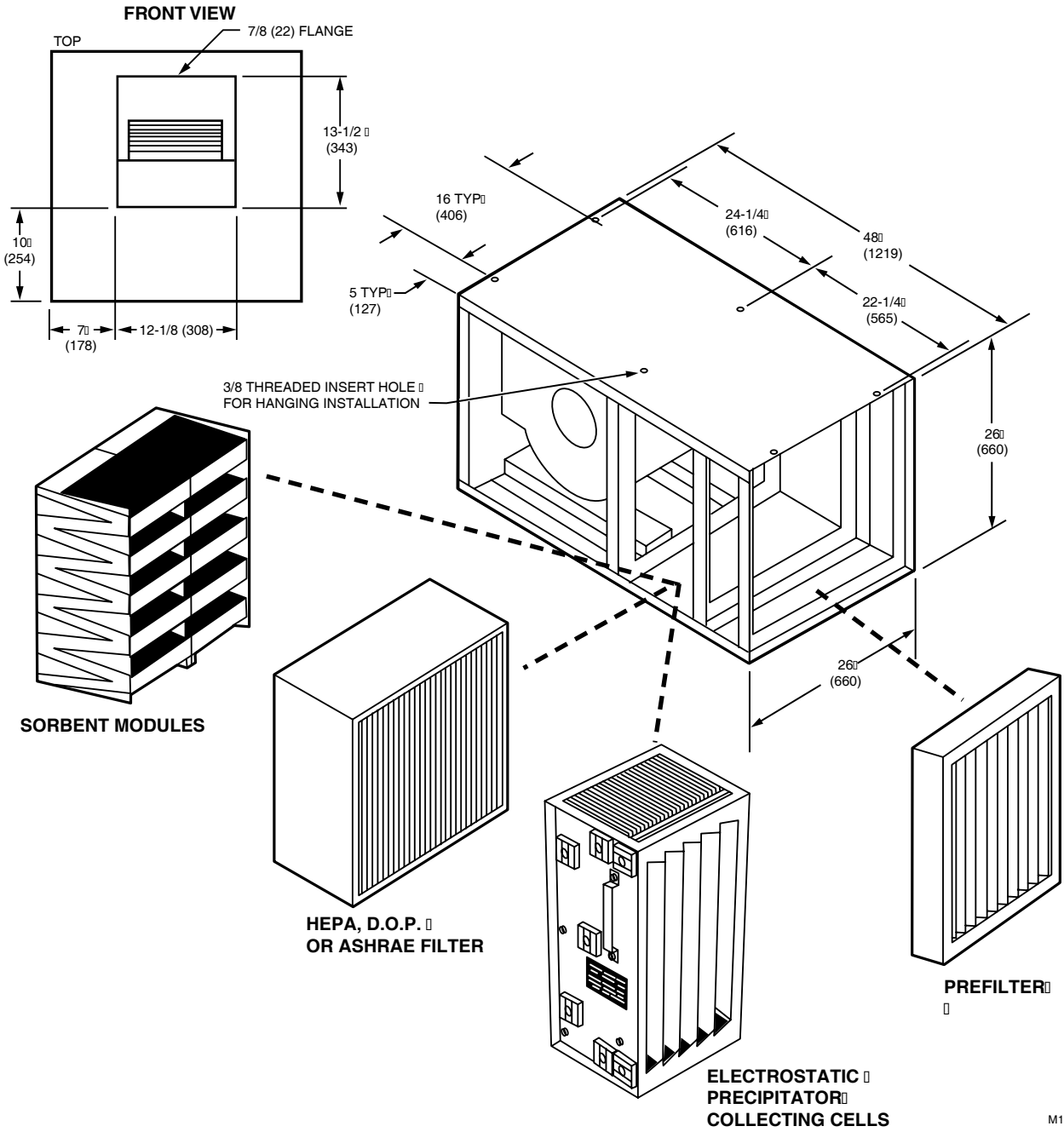

Fig. 1. Approximate dimensions of two stage filtering model in in. (mm).

Please Note : Electrostatic Precipitator Collecting Cells are no longer available.

F116 (SERIES 16000) SELF-CONTAINED DUCTABLE COMMERCIAL AIR CLEANER

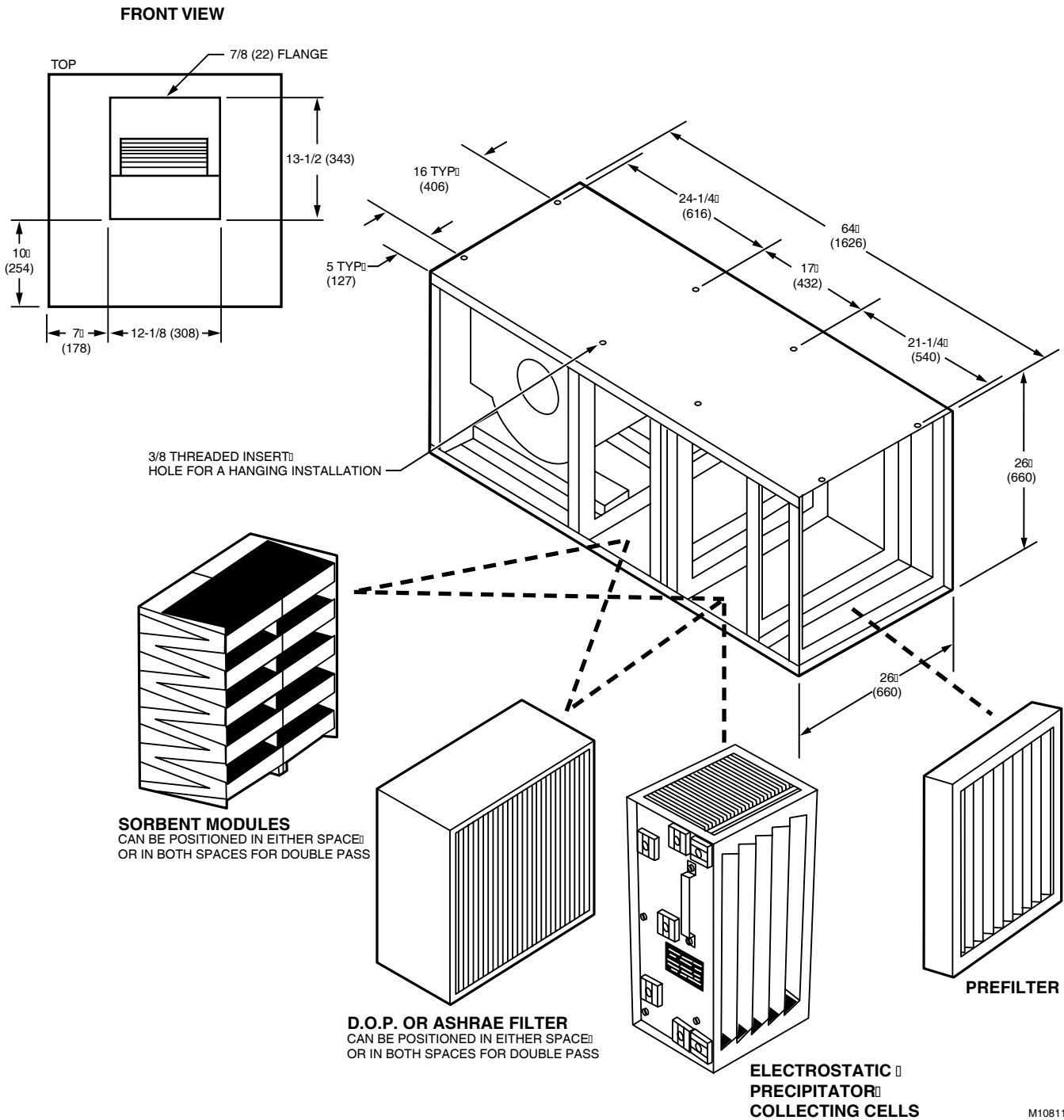

Fig. 2. Approximate dimensions of three stage filtering model in in. (mm).

Please Note : Electrostatic Precipitator Collecting Cells are no longer available.

PLANNING THE INSTALLATION

Application and Operation

The F116 (series 16000) self-contained ductable commercial air cleaner is designed for use in smoking areas, hospitals, in-plant office areas or plant satellite offices, printing shops, areas that do brazing, soldering or gluing and commercial cooking areas.

Because the air cleaner provides its own air circulation, it can be mounted in a duct system or independently. When used in a duct, the air cleaner air volume must be the same as the duct and plenum.

When the air cleaner is powered, the blower/motor draws the contaminated air into the air cleaner. Particles that are too small to be caught in the prefilter are trapped by the primary filter. The clean air is then discharged (two stage) or goes through a second primary filter (three stage) and is then discharged.

Static Pressure

The F116 (series 16000) uses a forward curve blower/motor. The electrical current draw is determined by combining the air volume to be moved with the filter and ducting static pressure.

IMPORTANT

Motor overload will occur if the combined filter and ducting static pressure is less than 1.2" W.G.

The net air volume at 1.2" W.G. will vary from 2150 cfm (62 m³/min) on low speed to 2350 cfm (68 m³/min) on high speed. The maximum allowable electrical current draw for all speeds is between 13.5A and 14A at 120 Vac.

The blower turns off when a sufficient amount of air can not be drawn through the intake (1.85" W.G.) and the blower spins in a vacuum. A maximum blower pressure of 2.25" W.G. can occur which can have an air volume of 100 cfm (3 m³/min).

NOTE: No damage will occur to the air cleaner if operating at 1.85" W.G. pressure or higher.

The ideal system design has the ducting pressure combined with a clean filter pressure operating at 1.2" W.G. The motor should run at 14A at 120V. As the filters load, the resistance to airflow increases which causes the static pressure to increase while the electrical current draw and air volume decrease. The air volume loss is low for the first 0.5" W.G. of pressure increase from the initial 1.2" W.G.

EXAMPLE: At high speed the 1.2" W.G. air volume is approximately 2350 cfm (68 m³/min) and at 1.7" W.G. the air volume is approximately 2000 cfm (58 m³/min). But at 1.9" W.G. the air volume drops to approximately 1150 cfm (33 m³/min).

Loading does not resist airflow when using the CPZ™ modules. However, a loaded prefilter does restrict the airflow. Refer to Fig. 3 and Table 3 for nominal air volume calculations and filter configuration pressures.

INSTALLATION

When Installing this Product...

! WARNING

- Remove packing materials from Blower Wheel prior to installation or initial power on.

- Read these instructions carefully. Failure to follow them could damage the product or cause a hazardous condition.
- Check the ratings given in the instructions and on the product to make sure the product is suitable for your application.
- Installer must be a trained, experienced service technician.
- After installation is complete, check out product operation as provided in these instructions.

FAN PERFORMANCE
DIRECT DRIVE BLOWER (12-5/8 x 9-1/2 WHEEL)
TESTED WITH 3 FT (0.9M) OUTLET DUCT

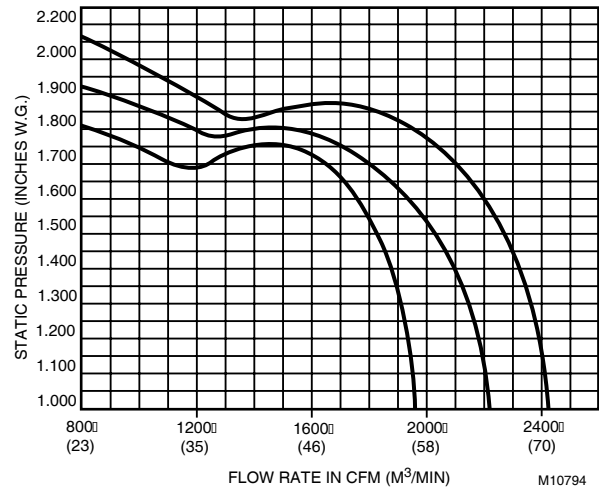

Fig. 3. Fan performance.

! CAUTION

- Do not connect the power source until after the air cleaner is mounted. This will prevent electrical shock or equipment damage.
- Be sure to turn off the air cleaner before servicing it.
- If the air cleaner must be turned on for an electrical check, be extremely careful to avoid electrical shock. Also, take care when working near the air cleaner moving parts.

Choose Location and Mount

Choose a location that is readily accessible for regular inspection and cleaning. Allow enough room for removing the prefilter and primary filters. Be sure there is room for servicing without removing pipes, ducts or other heating system components. See Fig. 4 through 12 for suggested locations.

The air cleaner must be attached to a structure capable of supporting the weight of the unit with filters, ducting and plenums when used. Roof trusses, bar joists and floor joists are examples of suitable structures.

IMPORTANT

All suspension points (either six or eight depending on the model) must be used for proper and safe installation. See Fig. 1 and 2 for dimensions between the suspension points.

Threaded rod, eyebolts with chains, or any standard practice and hardware for hanging method can be used in the suspension of the air cleaner. See Fig. 13.

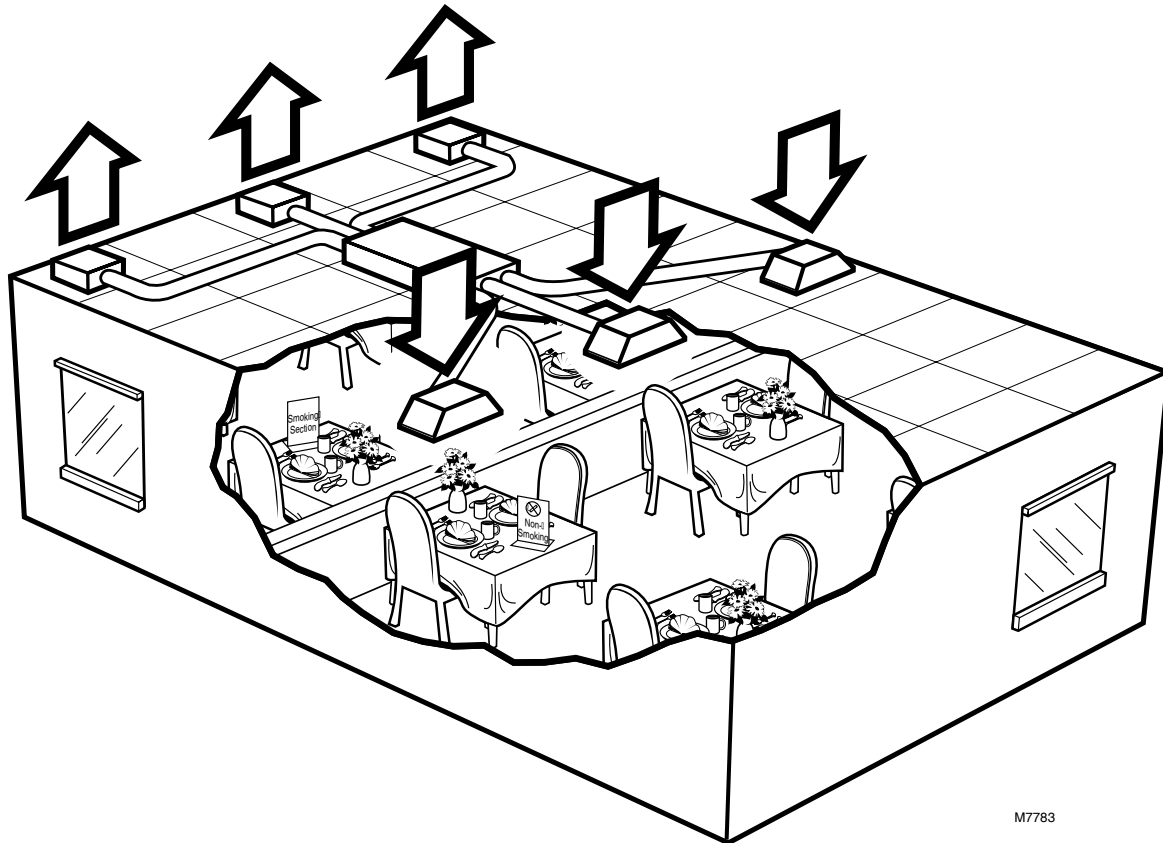

M7783

Fig. 4. Positioning air cleaners at the far end of the restaurant smoking section to draw the smoke away from the nonsmoking section.

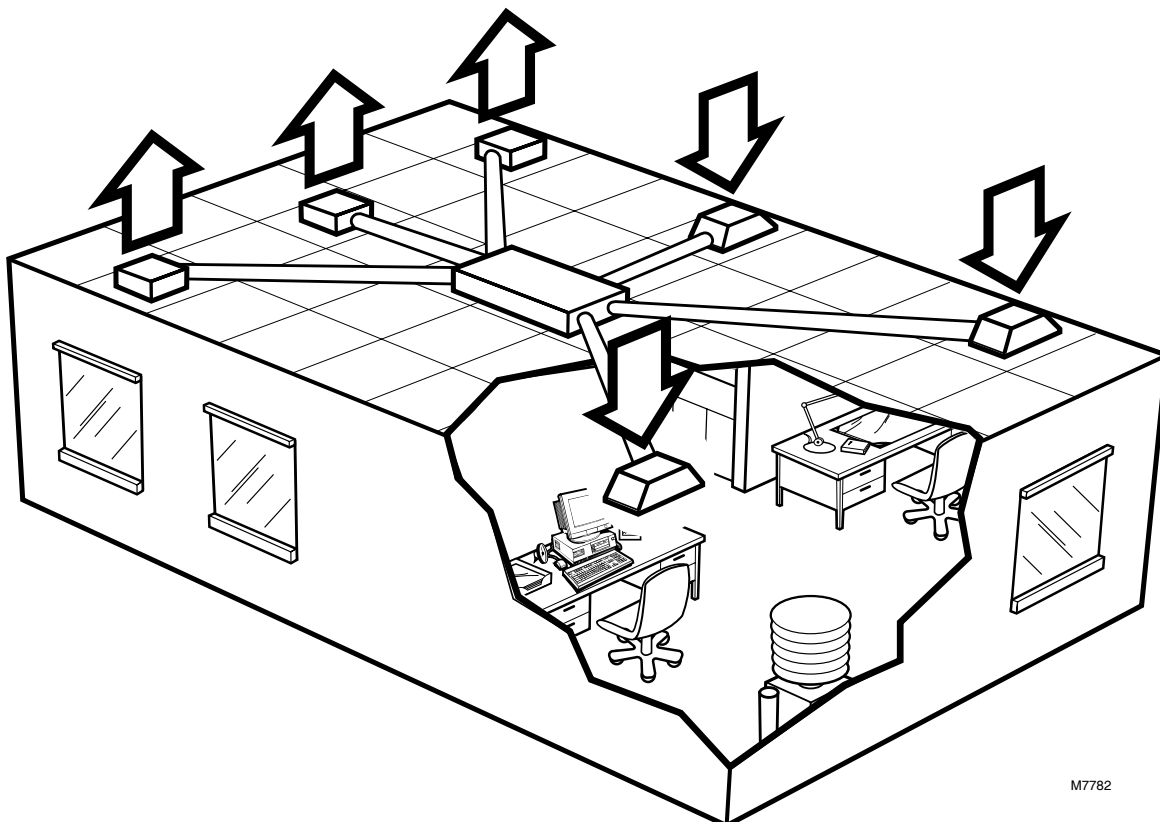

M7782

Fig. 5. Positioning air cleaners to create a negative pressure in polluted spaces and creating a positive pressure in nonpolluted areas. Use this positioning in in-plant offices and hospitals.

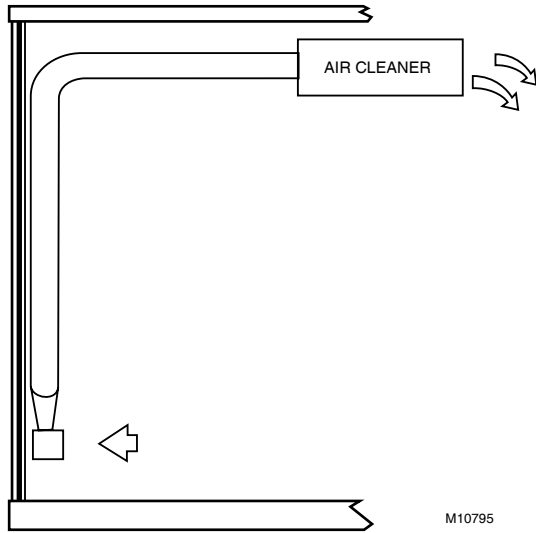

Fig. 6. Positioning air cleaner for printing shop, brazing, soldering or gluing vapor control.

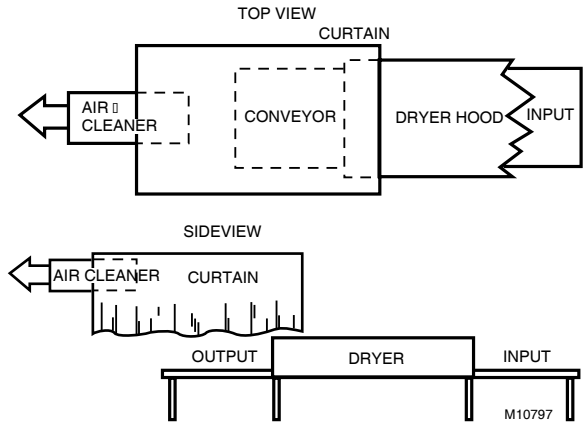

Fig. 8. Positioning air cleaner to remove pollutants from a conveyor feed process such as screen printing.

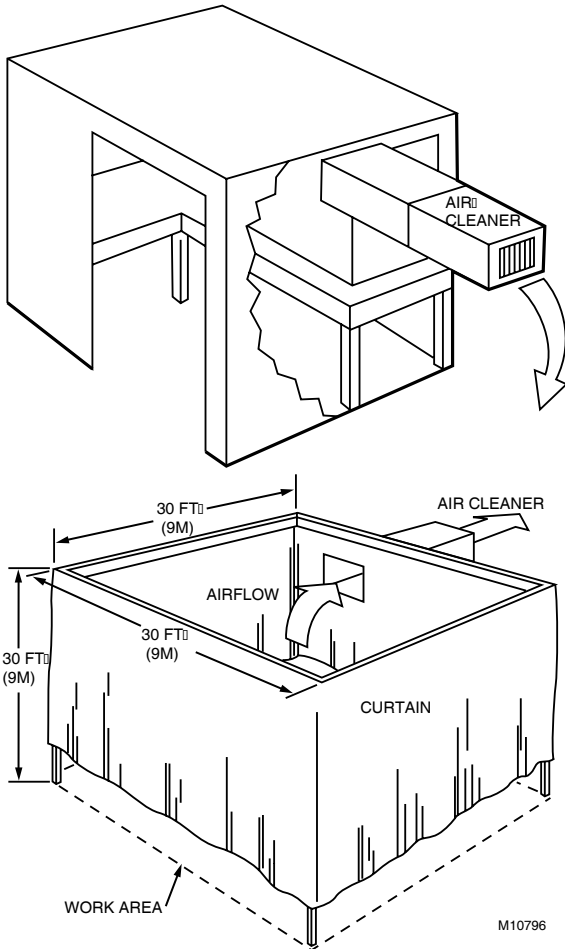

Fig. 7. Positioning air cleaner to create a negative pressure booth that contains a contamination generating process.

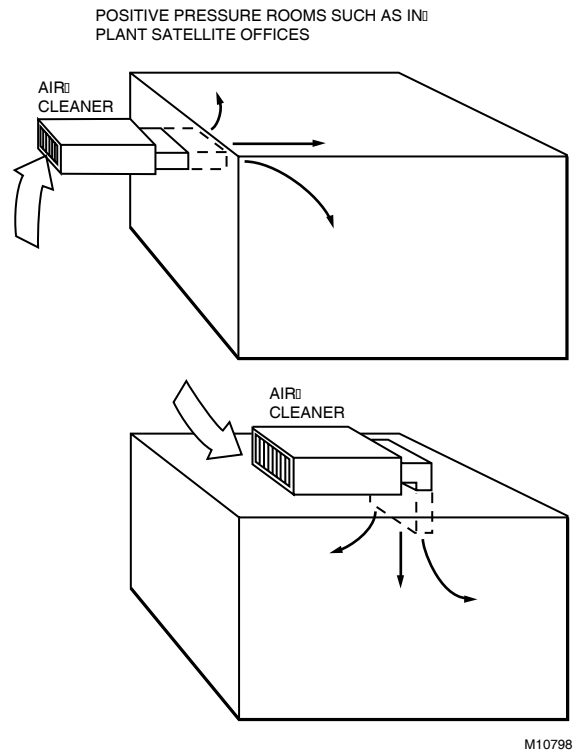

Fig. 9. Positioning air cleaner to create positive pressure for a plant satellite office.

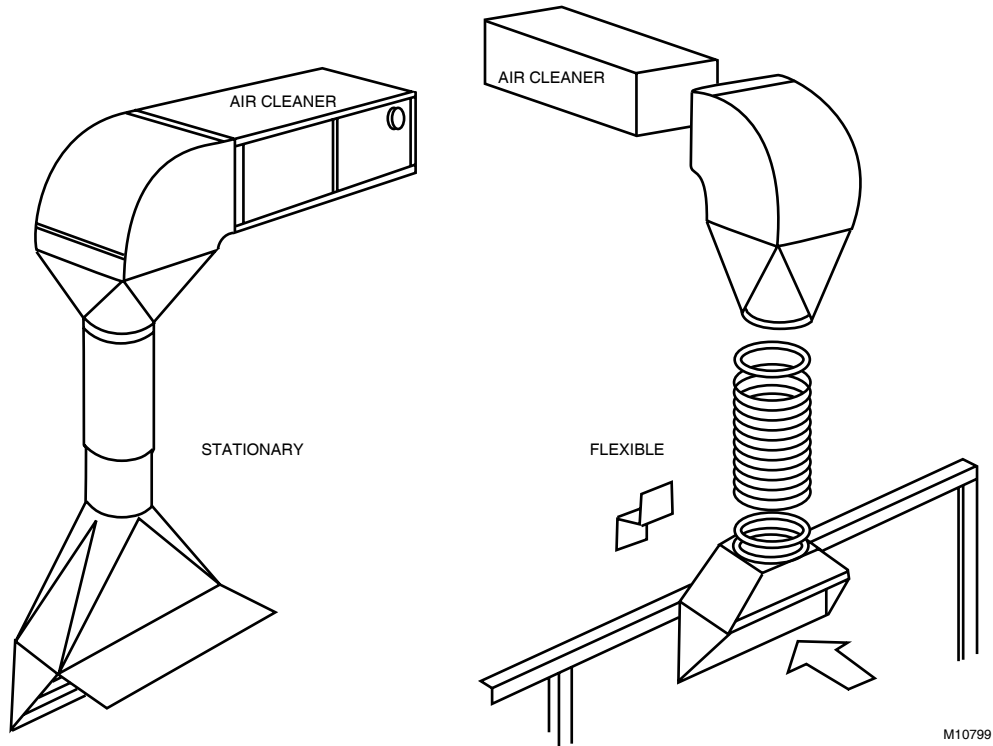

Fig. 10. Positioning air cleaner for suspended side draft applications.

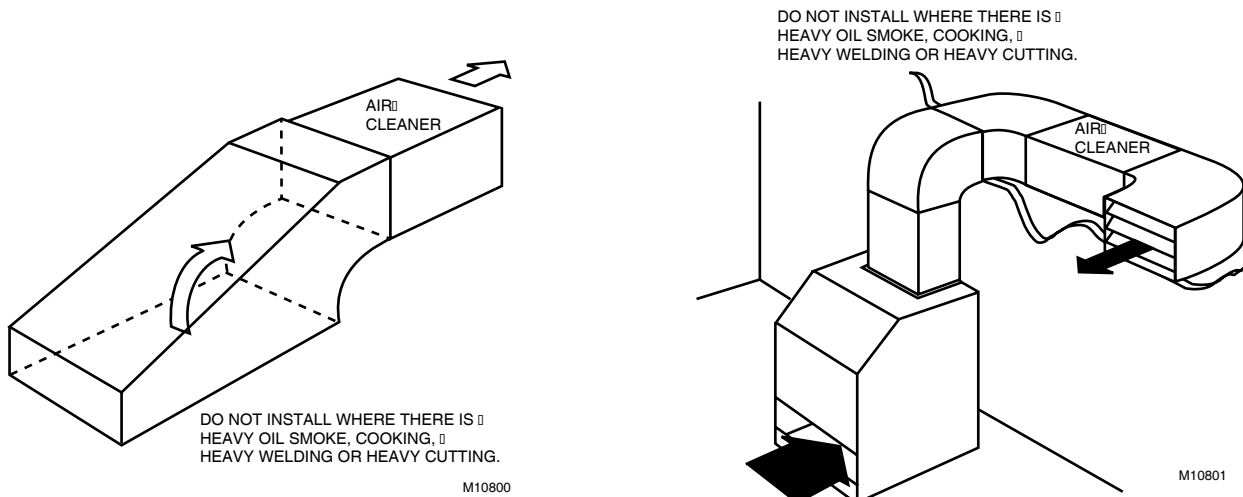

Fig. 11. Connecting air cleaner directly to a canopy hood with a minimum air entrance velocity of 120 fpm.

Fig. 12. Positioning air cleaner to recirculate existing exhaust system air which contains light to medium quantities of pollutants.

F116 (SERIES 16000) SELF-CONTAINED DUCTABLE COMMERCIAL AIR CLEANER

**FASTEN SECURELY TO STRUCTURAL SUPPORT SYSTEM
I.E. BAR JOIST, CONCRETE SLAB, TIMBER FRAMING, ETC.**

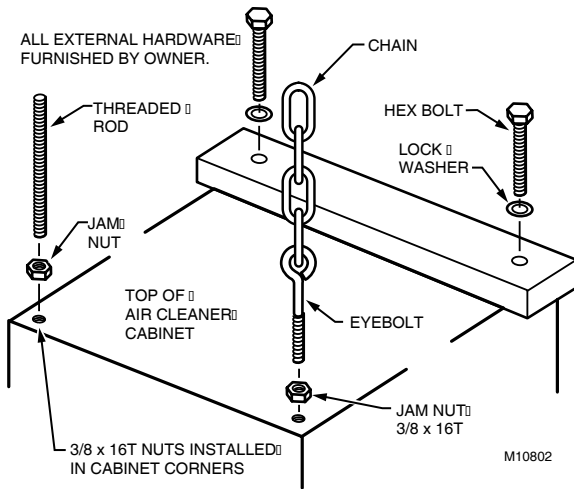

Fig. 13. Fastening air cleaner to a structural support system (bar joist, concrete slab or timber framing).

Install with Ducting

Use a transition or box plenum to attach the ducting to air cleaner inlet. A transition plenum is preferred. See Fig. 14. A diffusion screen must be installed when a box plenum is used. See Fig. 15. A box plenum can accommodate more than one inlet.

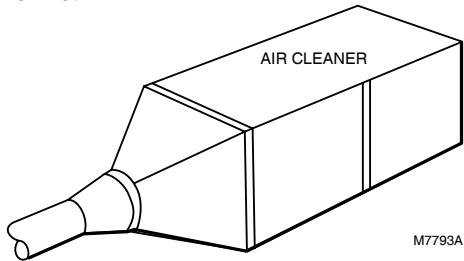

Fig. 14. Transition plenum connected to the air cleaner inlet.

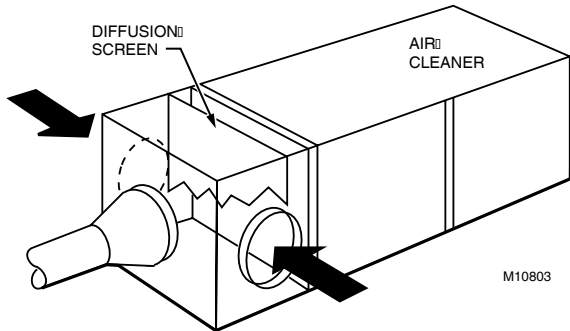
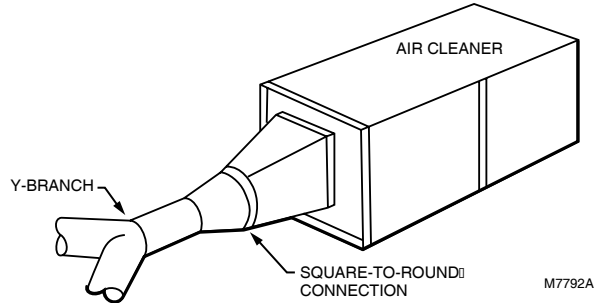

Fig. 15. Box plenum with diffusion screen and three inlets connected to the air cleaner.

Use a square-to-round or square-to-square connection when attaching the air cleaner outlet to the blower discharge flange. See Fig. 16. The outlet connection can be used with a Y-branch, distribution box or manifold as



required.

Fig. 16. Square-to-round connection attached to the air cleaner outlet.

Wire

All wiring must comply with applicable codes and ordinances. The power source must agree with the air cleaner electrical rating (120 Vac, 60 Hz; 220 Vac, 50/60 Hz).

1. Connect the power. See Fig. 17.

IMPORTANT

Ground the air cleaner for proper operation and safety.

2. Turn on the power and check that the blower operates at all three speed settings.
3. Check that the ON indicator lights when the fan is operating.
4. Turn off the power and install the filters in the cabinet.

NOTE: Select models have a disposable aluminum spacer. The spacer is necessary only when using the CPZ™ modules. All other filters need to remove and save the spacer for future needs.

5. Replace the air cleaner cover.

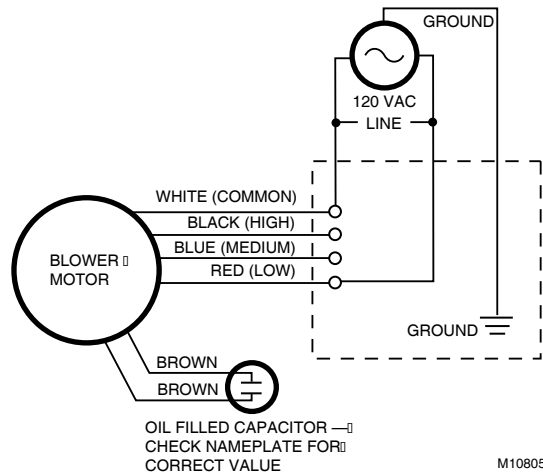

Fig. 17. F116A1021, F116A1047 and F116A1120 (120 Vac, 60 Hz); F116A1122, F116A2048, F116A2121 (220Vac, 50/60 Hz) air cleaner typical wiring diagram.

SERVICE

IMPORTANT

Air cleaners and components are susceptible to damage. Take care when working with them to avoid equipment damage.

The air cleaner removes a variety of particulate contaminants from the air. In the process of cleaning the air, the air cleaner filters become dirty and the cleaning efficiency is lowered.

To maintain a high standard of reliability and efficiency, it is necessary to periodically service the air cleaner. The maintenance is determined by the quantity and type of contaminants present and the frequency of air cleaner use. The frequency of servicing can only be established after a period of use.

NOTE: Some full-service distributors provide regular servicing to commercial establishments.



CAUTION

- Turn off power to the air cleaner.
- Stand on a stable platform when working with the air cleaner.

Maintenance

1. Remove the air cleaner cover and set it aside.
2. Remove the prefilter and primary filters.
3. Locate the blower/motor and apply 3 to 4 drops of light weight oil to the shaft bearings.

NOTE: Shaft bearings need oil once a year or every 3 or 4 months when the air cleaner operates 24 hours a day.

4. Use a detergent moistened cloth to annually wipe out the air cleaner cabinet.

Prefilter and Media Filters

1. Remove the air cleaner cover and set it aside.
2. Remove the prefilter and primary filters.
3. Check the prefilter and replace if it is fully coated with dust and lint (approximately every 1 to 3 months).
4. Replace the CPZ™ modules when a continuous noticeable odor is emitted from the air cleaner (approximately every 4 to 12 months).
5. Replace the particle or HEPA filter when there is a noticeable loss of air volume circulation (approximately every 10 to 24 months).
6. Reassemble the air cleaner and turn the power on.

TROUBLESHOOTING



WARNING

Electrical Shock Hazard

Can cause personal injury or equipment damage.

The following procedures expose hazardous live parts. Disconnect power supply between checks and proceed carefully.



CAUTION

The following instructions are for use by only qualified personnel.

See Table 5 for troubleshooting procedures.

Table 5. Troubleshooting the F116 (Series 16000) Air Cleaner.

Symptom	What to do
Motor will not start	<ul style="list-style-type: none"> * Check wiring for loose connections - tighten * Check capacitor - replace if necessary * Check for hot motor - thermal protection relay is tripped, reset it * Replace motor * Remove shipping packing from blower wheel
Vibration - High Frequency	Check that blower wheel is balanced - remove and balance or replace wheel
Vibration - Low Frequency	Check is system is operating above 2.0" W.G. pressure - reduce total pressure by replacing filters
Scraping noise	Check if the blower wheel is touching the blower housing - adjust blower and position wheel in the center of the inlet ring
Squeal or whistle noise	Check for air leaks in the cabinet doors or ducting - plug air leaks

F116 (SERIES 16000) SELF-CONTAINED DUCTABLE COMMERCIAL AIR CLEANER

PARTS LIST

Refer to Table 6 and Fig. 18 for the parts list and exploded view.

Table 6. F116 (Series 16000) Self-Contained Ductable Commercial Air Cleaner Parts List.

Fig. Reference No.	Description	Pack Qty	Order Number	Reference No.
1	Prefilter	1 Box of 6	32000200	860039
2	Primary Filters:			
	HEPA filter (99.97%)	1	32000198	860023
	D.O.P. filter (95%)	1	32000195	860024
	ASHRAE dust spot filter (95%)	1	32000196	860025
	ASHRAE dust spot filter (65%)	1	32000197	860026
	CPZ sorbent module (requires 2)	1	32004078-001	N/A
	Charcoal only sorbent module (requires 2)	1	32004078-002	N/A
	Zeolite only sorbent module (requires 2)	1	32004078-003	N/A
	Permanganate only sorbent module (requires 2)	1	32004078-004	N/A
Parts not shown				
3	Blower/motor, 120V	1	32000552-001	N/A
	Blower/motor, 220V	1	32000552-002	N/A
4	Capacitor	1	32000551-001	N/A

F116 (SERIES 16000) SELF-CONTAINED DUCTABLE COMMERCIAL AIR CLEANER

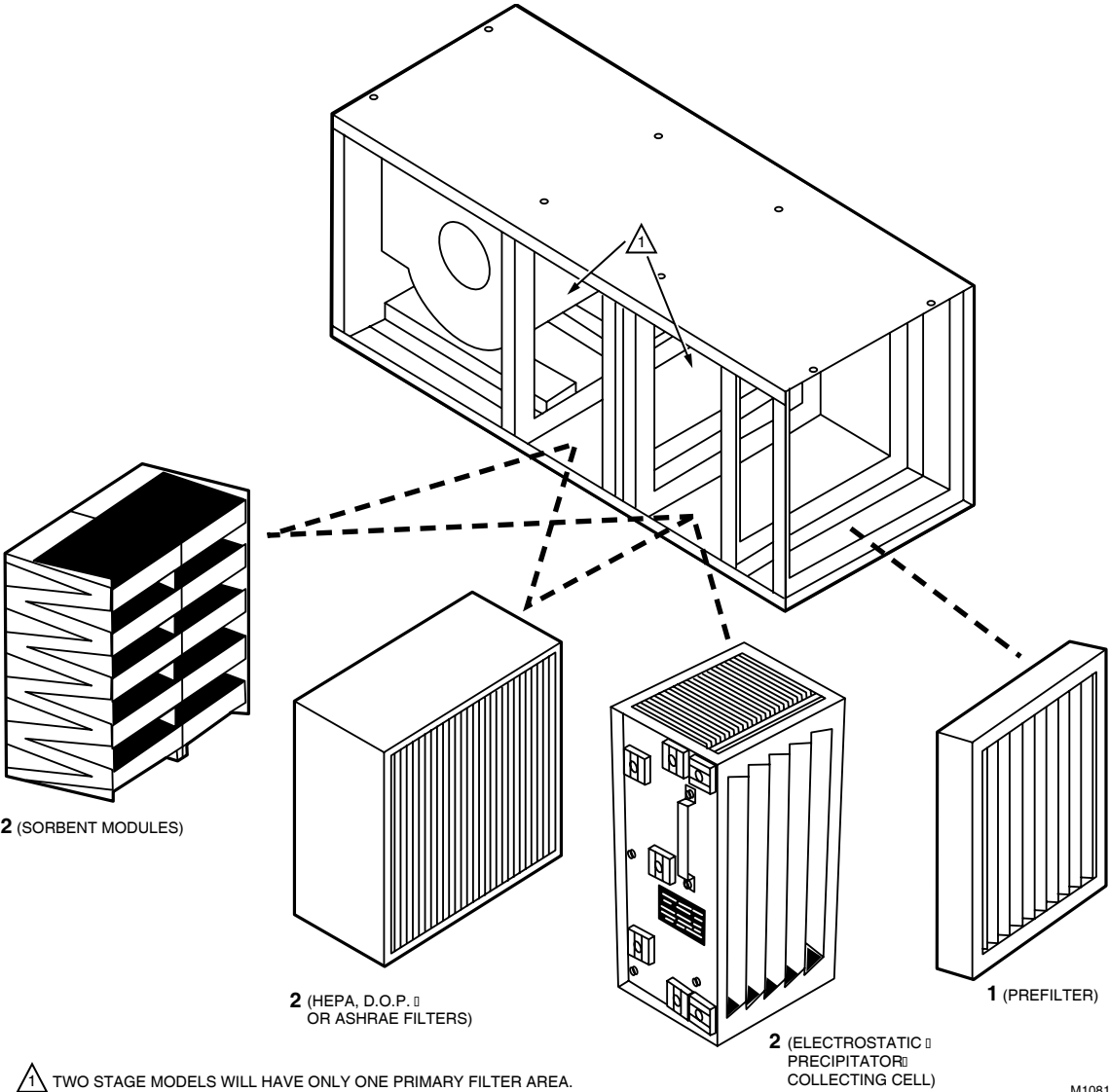

Fig. 18. Exploded view of F116 (series 16000) self-contained ductable commercial air cleaner components.

Please Note : Electrostatic Precipitator Collecting Cells are no longer available.

LIMITED TWO-YEAR WARRANTY

Air-Pure Systems warrants its air cleaner products to be free from defects in workmanship or materials under normal use and service, for a period of two (2) years from the date of purchase by the original end-user. If at anytime during the warranty period the product is defective or malfunctions, Air-Pure Systems, through the distributor or dealer, from which the product was purchased, or through an authorized warranty repair station, shall at Air-Pure Systems option, replace or repair the defective product or component.

This warranty does not cover removal or installation costs. This warranty shall not apply if it is shown that the defect or malfunction was caused by damage which occurred during handling or shipment, improper electrical connections, improper use of the product or abuse.

Air-Pure Systems sole responsibility shall be to repair or replace the product within the terms stated above. **AIR-PURE SYSTEMS SHALL NOT BE LIABLE FOR ANY LOSS OR DAMAGE OF ANY KIND, INCLUDING ANY INCIDENTAL OR CONSEQUENTIAL DAMAGES RESULTING, DIRECTLY OR INDIRECTLY, FROM ANY BREACH OF WARRANTY, EXPRESS OR IMPLIED, OR ANY OTHER FAILURE OF THIS PRODUCT.** (Some states do not allow the exclusion or limitation or incidental or consequential damages, so this limitation may not apply to you.). **THE WARRANTIES SET FORTH HEREIN ARE EXCLUSIVE AND AIR-PURE SYSTEMS EXPRESSLY DISCLAIMS ALL OTHER WARRANTIES, WHETHER WRITTEN OR ORAL, IMPLIED OR STATUTORY, INCLUDING BUT NOT LIMITED TO ANY WARRANTIES OR MERCHANTABILITY, WORKMANSHIP, OR FITNESS FOR A PARTICULAR USE.**

This warranty gives you specific legal rights and you may have other rights which vary from state to state.

How to make a warranty claim or have questions answered:

Should you have a warranty claim or questions about the warranty policy, contact the distributor or dealer from which you purchased the product or the authorized warranty repair stations nearest your location.

NOTE: Do not return any products or parts to the factory without a factory issued "Return Warranty Good Label" issued by Air-Pure Systems.

In the event you or other persons, have any questions concerning the use and care of this product of this warranty please call or write the factory.

Air-Pure Systems

16873 Fish Point Rd. SE
Prior Lake, MN 55372-1714
Phone: (800) 998-1919
Fax : (800) 221-3248

Air-Pure Systems

16873 Fish Point Rd. SE
Prior Lake, MN 55372-1714
Phone: (800) 998-1919
Fax: (800) 221-3248