

F57A,B Flush-Mount Commercial Electronic Air Cleaner

PRODUCT DATA



GENERAL

The F57A,B Flush-Mount Commercial Electronic Air Cleaners are ceiling-mounted. The F57 removes airborne contaminants such as tobacco smoke and dust from the air circulated through the F57.

FEATURES

- Removes staining dirt from the air as measured by the Dust Spot Method using atmospheric dust; refer to the American Society of Heating, Refrigerating, and Air Conditioning Engineers Standard 52.1-92.
- Three-speed motor-driven fan circulates up to 1030 cfm (1750 m³/hr) on F57A, up to 485 cfm (714 m³/hr) on F57B.
- Solid state power supply is self-regulating and maintains peak efficiency during a wide range of cell dirt loading conditions.
- Interlock switch prevents operation when the grille is open.
- Heavy duty commercial cells and prefilter are removable for cleaning.
- Air vent provides dilution control of gaseous contaminants.
- Provides Coanda air distribution by drawing in dirty air, cleaning it electronically, and recirculating the clean air in six directions throughout the space.
- Light emitting diodes (LEDs) indicate ON and CHECK; the WASH LED is optional.
- Test button shows the presence of high voltage.
- Available in 120 Vac, 60 Hz or 220–240 Vac, 50 Hz models.
- Optional wall mounted remote switch.
- Optional hand-held infrared remote transmitter controls up to nine F57s via infrared remote receivers. Some models available with infrared receiver factory installed.
- Optional activated carbon filters controls ozone and reduces occasional gaseous contamination.

• READ AND SAVE THESE INSTRUCTIONS

Contents

General	1
Features	1
Specifications	2
Ordering Information	2
Planning the Installation	4
Installation	7
Checkout	10
Service	11
Electrical Troubleshooting	15
Parts List	19
Limited One-Year Warranty	24

The Honeywell Trademark is used under license from Honeywell International Inc. by Air-Pure Systems. Honeywell International Inc. makes no representations or warranties with respect to this product.

F57A,B FLUSH-MOUNT COMMERCIAL ELECTRONIC AIR CLEANER

SPECIFICATIONS

IMPORTANT

The specifications given in this publication do not include normal manufacturing tolerances. Therefore, this unit may not exactly match the listed specifications. This product is tested and calibrated under closely controlled conditions, and some minor differences in performance can be expected if those conditions are changed.

Models:

F57A Flush-Mount Commercial Electronic Air Cleaner: contains two FC37B heavy duty commercial cells, power supply assembly, prefilter, inlet-outlet grille, power and speed control switch, performance selection switch, collector test button, 3-speed motor driven fan, interlock switch for the access grille, vinyl trim flanges, exhaust air vent and LED indication of system operation.

F57B Flush-Mount Commercial Electronic Air Cleaner: same as F57A, except with only one FC37B heavy duty commercial cell.

Color:

Off-white.

Solid State Power Supply Assembly:

203361A,B (F57A); 203361C,D (F57B).

Electrical Ratings:

Voltage and Frequency: 120 Vac, 60 Hz; 220–240 Vac, 50 Hz.

Current and Power Consumption:

	Fan Setting	120 Vac, 60 Hz		220/240 Vac, 50 Hz	
		A	W	A	W
F57A	HI	3.9	315	1.8	315
	MED	3.2	300	1.4	250
	LOW	2.4	200	1.2	205
F57B	HI	4.3	255	1.9	275
	MED	2.1	185	1.0	150
	LOW	1.2	85	0.7	100

ORDERING INFORMATION

If you have additional questions, need further information, or would like to comment on our products or services, please contact:

- Your local Honeywell Commercial Air Products Distributor**
- Air-Pure Systems.**
16873 Fish Point Rd. SE
Prior Lake, MN 55372-1714
Phone: (800) 998-1919
Fax: (800) 221-3248
www.cleanairfacility.com

Air Flow Capacity:

	Fan Setting	120 Vac, 60 Hz		220/240 Vac, 50 Hz	
		cfm	m ³ /min	cfm	m ³ /min
F57A	HI	1030	29	875	25
	MED	690	20	730	21
	LOW	555	16	640	18
F57B	HI	485	14	460	13
	MED	280	8	375	11
	LOW	175	5	260	7

Efficiency:

Up to 95% efficiency using the Dust Spot Method measuring atmospheric dust, according to the American Society of Heating, Refrigeration, and Air Conditioning Engineers (ASHRAE) Standard 52.1-92.

Motor:

F57A: 1/12 hp; sealed ball bearing.
F57B: 1/10 hp; sealed ball bearing.
Motor lubrication is not required.

Ambient Temperature Rating:

Shipping and Storage: minus 20°F to plus 150°F (minus 29°C to plus 66°C).

Operating: this equipment is intended for use at ambient temperatures which are usually not higher than 77°F (25°C) but occasionally may be as high as 104°F (40°C) for brief periods.

Dimensions:

See Figs. 1 and 2 for dimensions.

Shipping and Installation Weight:

	F57A		F57B	
	lb	kg	lb	kg
Heavy Duty Commercial Cell (Each)	9.5	4.3	9.5	4.3
Shipping Weight	106.0	48.1	64.0	29.0
Installed Weight	83.0	37.6	54.0	24.5

F57A,B FLUSH-MOUNTED COMMERCIAL ELECTRONIC AIR CLEANER

Approvals:

Underwriters Laboratories Inc. Listed: File no. E30954,
 Guide no. AGGZ.
 Canadian Standards Association Listed: File no.
 LR19060.
 The F57A,B Flush-Mounted Commercial Electronic Air
 Cleaners meet all European Directives.

Replacement Parts and Accessories:
 See Parts List on page 19.

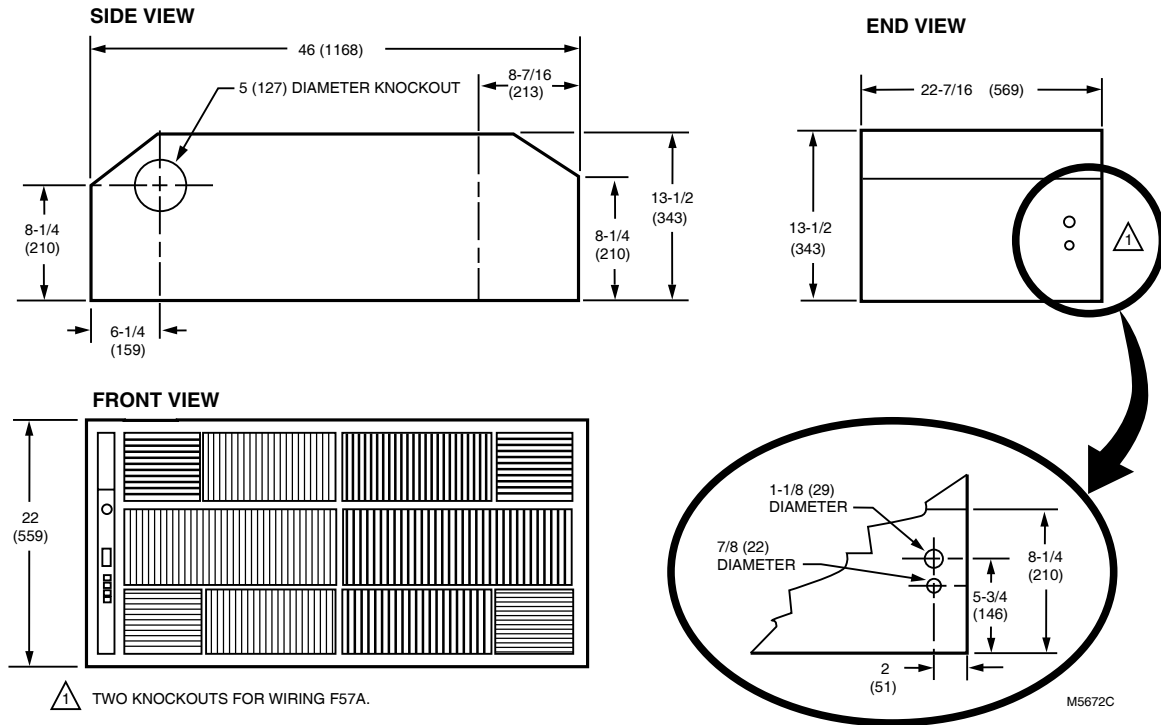

Fig. 1. Approximate dimensions of F57A in in. (mm).

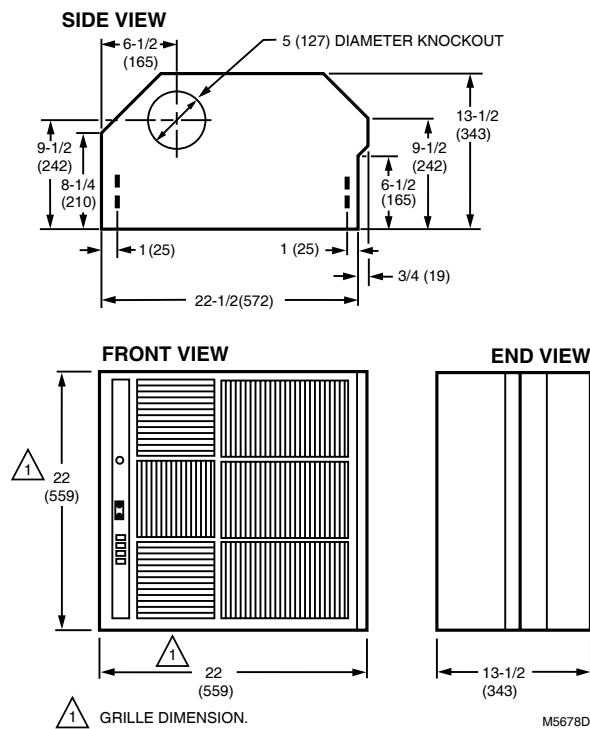

Fig. 2. Approximate dimensions of F57B in in. (mm).

PLANNING THE INSTALLATION

⚠ WARNING

Explosion Hazard Possible
Can cause personal injury or equipment damage.
 Do not install or use the F57 where there is any danger of gas, vapor, or dust explosion.

Do not install when explosion-proof electrical fixtures are specified.

Application and Operation

The F57 Flush-Mount Electronic Air Cleaner is designed for use in restaurants, conference rooms, lounges, and offices where overhead air cleaning is required.

Because the F57 provides its own air circulation, it can be used in any situation that requires the removal of contamination from an enclosed area.

Because it is not explosion-proof, the F57 must not be used if there are dangerous levels of potentially explosive vapors, gases, or dusts present in the cleaning area.

When the electronic air cleaner is powered, the fan draws the contaminated air into the electronic air cleaner. Particles that are too small to be caught in the prefilter are given an intense electrical charge in the ionizer section of the electronic cell. As the air passes through the collecting section of the cell, the charged particles adhere to the collector plates, which have a strong opposite charge. The cleaned air passes through the fan component and re-enters the building space.

Two light-emitting diodes LED(s), ON and CHECK, are included with the F57. The ON LED lights when the solid-state power supply is powered and operating normally. The CHECK LED lights if the F57 requires service attention or if the test button is pressed. A WASH LED is also supplied with the F57 but it is not factory installed. It can be field installed using 4074 EMH Bag Assembly which is supplied with the F57. See Fig. 4. The WASH LED lights to indicate cell washing is overdue.

Determine Number of F57s Needed

The sizing procedure determines the number of F57As or Bs needed. The correct number required for a particular application depends on:

- type of contamination,
- number of occupants,
- volume of the room,
- use of the room,
- outdoor air quality.

This sizing information (Fig. 3) was generated using the ASHRAE Handbook of Fundamentals, 1985; the ASHRAE Standard 62-1989, Ventilation for Acceptable Indoor Air Quality. It simplifies the sizing procedure for most applications. Use this information as a guide; however, remember that the F57 has different capacities for each fan speed; see Specifications section.

The number of air changes per hour determines the amount of air cleaning obtained. More air changes per hour than recommended in the graph above are unnecessary because the ASHRAE data used in the calculation is conservative. Fewer air changes per hour than recommended in the graph can be compensated for by bringing in more outdoor air to maintain low contaminant levels, or tolerating a partially cleaned atmosphere, which may be acceptable to some users.

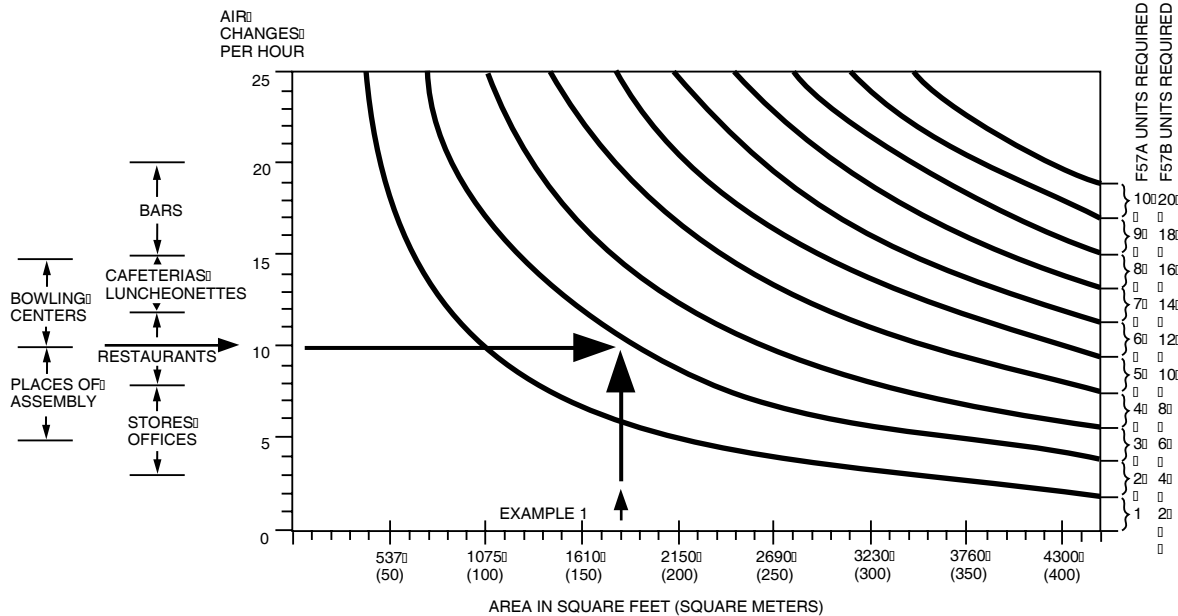

TO USE THE GRAPH:

1. EXTEND A HORIZONTAL LINE FROM THE DESIRED NUMBER OF AIR CHANGES PER HOUR, UNTIL IT INTERSECTS WITH A VERTICAL LINE DRAWN UPWARD FROM THE NUMBER OF SQUARE FEET OF THE ROOM.
2. READ THE NUMBER OF UNITS REQUIRED AT THE INTERSECTION POINT.

M1206B

Fig. 3. F57 sizing by air changes per hour and room area. In most cases, one F57B is equivalent to half an F57A because the F57B airflow, although less than 50 percent of F57A airflow, is more effectively applied via several locations.

EXAMPLE 1: Sizing by air changes per hour and room area (using the graph in Fig. 3).
An office measures 40 x 45 ft (12 x 14m). How many F57 air cleaners should be installed?

SOLUTION:

1. Find the floor area.
 $40 \text{ ft} \times 45 \text{ ft} = 1800 \text{ ft}^2$ ($12 \text{ m} \times 14 \text{ m} = 168 \text{ m}^2$).
2. Assuming ten air changes per hour, with an 1800 ft^2 (168 m^2) area, the graph (Fig. 3) indicates a requirement for two F57A units, or four F57B units.

EXAMPLE 2: Sizing by occupant load.
A cocktail lounge averages 75 occupants. How many F57 air cleaners should be installed?

SOLUTION: Number of F57s required =

$$\frac{\text{ASHRAE Recommended Air Circulation/Min}}{\text{F57 Capacity}}$$

1. ASHRAE recommended minimum air circulation is 35 cfm ($1 \text{ m}^3/\text{min}$) per person. For 75 people, the recommended air circulation would be: $75 \text{ people} \times 35 \text{ cfm} (1 \text{ m}^3/\text{min}) \text{ per person} = 2625 \text{ cfm} (75 \text{ m}^3/\text{min})$.
2. F57A capacity (HI setting) is $1030 \text{ ft}^3/\text{min}$ ($29 \text{ m}^3/\text{min}$).
Number of F57As required = $2625 \text{ ft}^3/\text{min} / 1030 \text{ ft}^3/\text{min} = 2.5$ or 3 units.
or
F57B capacity (HI setting) is 485 cfm ($14 \text{ m}^3/\text{min}$).
Number of F57Bs required = $2625 \text{ ft}^3/\text{min} / 485 \text{ ft}^3/\text{min} = 5$ units.

EXAMPLE 3: Sizing by air changes per hour and room volume.
A shop proprietor wants to use electronic air cleaning to remove high levels of smoke from the air. The shop is 25 x 40 ft (8 x 12m) with a 15 ft (4.5m) ceiling. How many F57 air cleaners will be required?

GUIDELINE: In the absence of other information, select the correct number of F57 units to provide between 10 or 20 air changes per hour, depending on contaminant level. The air cleaner should be located directly above or as close as possible to the source of contamination.

SOLUTION: Number of F57s required =

$$\frac{\text{Desired Air Circulation/Min}}{\text{F57 Capacity}}$$

1. Calculate the volume of the room.
 $25 \text{ ft} \times 40 \text{ ft} \times 15 \text{ ft} = 15,000 \text{ ft}^3$
($8 \text{ m} \times 12 \text{ m} \times 4.5 \text{ m} = 432 \text{ m}^3$).
2. Determine the volume of air to be circulated each hour. Ten air changes per hour are used here on the assumption that the intent is to reduce, but not completely eliminate, smoke.

$$15,000 \text{ ft}^3 \times 10 \text{ air changes per hour} = 150,000 \text{ ft}^3/\text{hr}$$

$$(432 \text{ m}^3 \times 10 \text{ air changes per hour} = 4320 \text{ m}^3/\text{hr}).$$

Then determine the volume of air to be circulated each minute.

$$\frac{150,000 \text{ ft}^3/\text{hr}}{60 \text{ min/hr}} = 2500 \text{ ft}^3/\text{min}$$

$$\frac{4320 \text{ m}^3/\text{hr}}{60 \text{ min/hr}} = 72 \text{ m}^3/\text{min}$$

3. F57A capacity (HI setting) is $1030 \text{ ft}^3/\text{min}$ ($29 \text{ m}^3/\text{min}$).
Number of F57As required = $\frac{2500 \text{ ft}^3/\text{min}}{1030 \text{ ft}^3/\text{min}} = \frac{72 \text{ m}^3/\text{min}}{29 \text{ m}^3/\text{min}} = 2.4$ or 3 units.
or
F57B capacity (HI setting) is 485 cfm ($14 \text{ m}^3/\text{min}$).
Number of F57Bs required = $\frac{2500 \text{ ft}^3/\text{min}}{485 \text{ ft}^3/\text{min}} = \frac{72 \text{ m}^3/\text{min}}{14 \text{ m}^3/\text{min}} = 5$ units.

Regardless of the method used for calculation, the physical limitations of the space to be cleaned can influence the number of electronic air cleaners required. For ambient air cleaning, it is essential to establish a uniform airflow pattern throughout the entire space. Fewer electronic air cleaners can be installed because of a lack of mounting space. More units may be required due to an oddly-shaped room that does not lend itself to an even airflow.

If any questions should arise concerning size, consult your distributor or local Honeywell Commercial Air Cleaner Distributor.

Choose Location

The F57 is mounted horizontally, and can be used in almost any air cleaning application that has a suspended ceiling. For the most efficient operation, place the F57 as close as possible to the contaminant source.

When placing the F57, be sure that the clean air discharge enhances the airflow patterns of the area to be cleaned. For example, do not place the air cleaner so its discharge disrupts the flow from the central air handling system supply registers.

The shape of the room, location of central air conditioning diffusers and returns, architectural features, and ceiling obstruction will affect optimum F57 location in the ceiling.

For partial dilution of odor and gaseous contaminant, some F57 discharge air can be bled off into the area above the suspended ceiling, or a run of 12 ft (3.7m) or less of 5 in. (127 mm) round duct can be vented outdoors or to an exhaust duct that is always at negative pressure.

Determine if the air vent of the unit must be ducted to the return air plenum (as some local building codes require). For duct connection, make sure the access panel to the vent is removed so a 5 in. (127 mm) diameter duct can be connected to the collar (collar is field supplied).

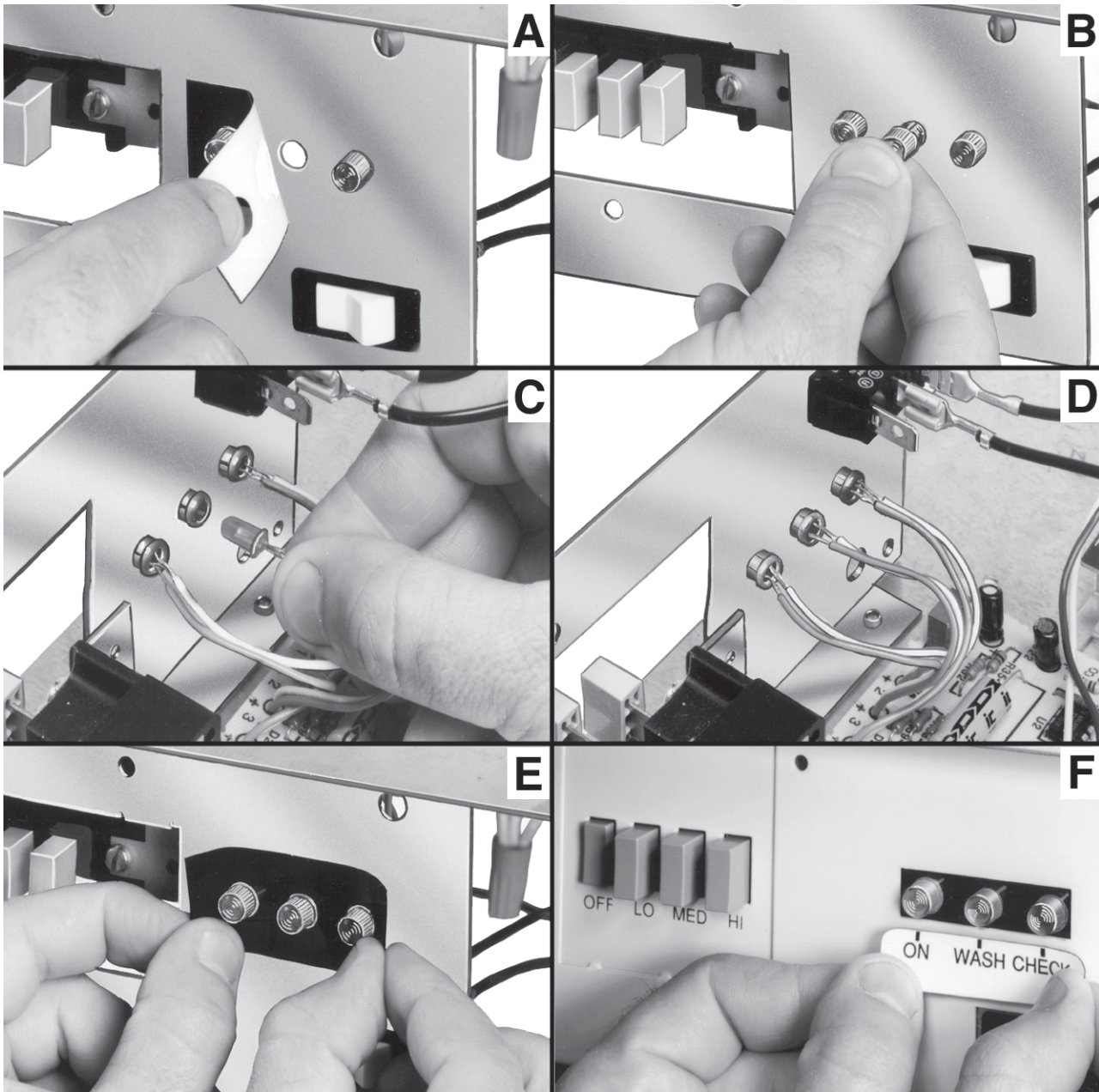

Fig. 4. Installing Optional Wash LED.

INSTALLATION

When Installing this Product...

1. Read these instructions carefully. Failure to follow them could damage the product or cause a hazardous condition.
2. Check the ratings given in the instructions and on the product to make sure the product is suitable for your application.
3. If the air cleaner is to be functionally checked before installation, be extremely careful to avoid electrical shock. Also, take care when working near the air cleaner's moving parts. Ensure power is disconnected before installation.
4. Installer must be a trained, experienced service technician.
5. Installation and wiring must conform to current regulations. In Europe, a qualified electrician must supervise wiring.
6. In Europe, the air cleaner must be supplied via a double pole isolating switch with a contact separation of at least 3mm in each pole.
7. **WARNING:** This air cleaner must be earthed (grounded).
8. This air cleaner is designated for use in commercial premises; it is not intended for use in domestic applications.
9. Ensure minimum fresh air supply is maintained based on the type of premises and occupancy. Refer to local standards and codes of practice.
10. After installation is complete, check out air cleaner operation as provided in these instructions.



WARNING

Explosion Hazard Possible
Can cause personal injury or equipment damage.
 Do *not* install or use the F57A,B where there is any danger of gas, vapor, or dust explosion.

This unit has not been investigated for use in the ceilings of fire-resistant assemblies.



CAUTION

- Do not connect the power source until after electronic air cleaner is mounted. This will prevent electrical shock or equipment damage.
- Be sure to turn off the air cleaner before servicing it. The air cleaner motor is equipped with an automatic thermal overload. If the motor becomes overheated, it will automatically stop. It will automatically start after a sufficient period of cooling (several minutes to an hour).
- If the air cleaner must be turned on for an electrical check, be extremely careful to avoid electrical shock. Also, take care when working near the air cleaner moving parts.
- When installing the air cleaner in the ceiling, wear gloves for hand protection.

Unpack F57 Commercial Electronic Air Cleaner



WARNING

Sharp Edges

Can cause personal injury.

Handle air cleaner carefully to avoid cuts from sharp metal edges. Wear protective gloves.

- Remove the grille assembly.
- Remove the prefilter and electronic cells from the electronic air cleaner; set aside.
- Remove the electronic air cleaner from the box; remove the four screws on the back of the cleaner, and discard. This releases the fan motor into a floating suspension that minimizes noise.
- Remove all shipping cardboard and cell containers inside and outside of the air cleaner components. Inspect packing material before discarding to be sure no parts or papers are lost.
- If installing optional WASH LED, remove power supply cover. Refer to Fig. 4 and the corresponding steps below:
 - A. Remove black two-hole label from switch bracket.
 - B. Snap the LED holder into the center hole, mounting from the front side of the switch bracket.
 - C./D. Snap the LED into the back of the LED holder.
 - E. Apply plain three-hole label included onto the switch bracket.
 - F. Replace power supply cover and apply printed label (included) to power supply cover.

Optional Exhaust Air Vent

Remove the five-inch knockout on the side of the F57 when using the exhaust air vent option. Purchase a five-inch collar locally and insert into the opening. Bend tabs to secure the collar.

Mount F57 Commercial Electronic Air Cleaner



WARNING

Heavy Equipment

Can cause personal injury or equipment damage.

When the F57A,B is not reinforced as explained below, structural weakening, buckling, or the unit falling may cause personal injury and equipment damage.

Mount the F57A,B as part of a suspended ceiling, with a minimum of 14 in. (356 mm) between the suspended ceiling and the true ceiling. See Figs. 5 and 6.

Forty feet (12.2m) of 12 gauge wire is included for adding support to the dropped ceiling T-bars. Also included are four support shoulders, four rubber mounting spacers, and four panhead bolts with self-locking nuts.

- Remove the tile(s) from the suspended ceiling for a space approximately 24 x 48 in. (610 x 1220 mm) for F57A, or 24 x 24 in. (610 x 610 mm) for F57B. The area between the suspended ceiling and the true ceiling must be at least 14 in. (356 mm) and clear of ducts, pipes, and other obstacles and encumbrances.

F57A,B FLUSH-MOUNT COMMERCIAL ELECTRONIC AIR CLEANER

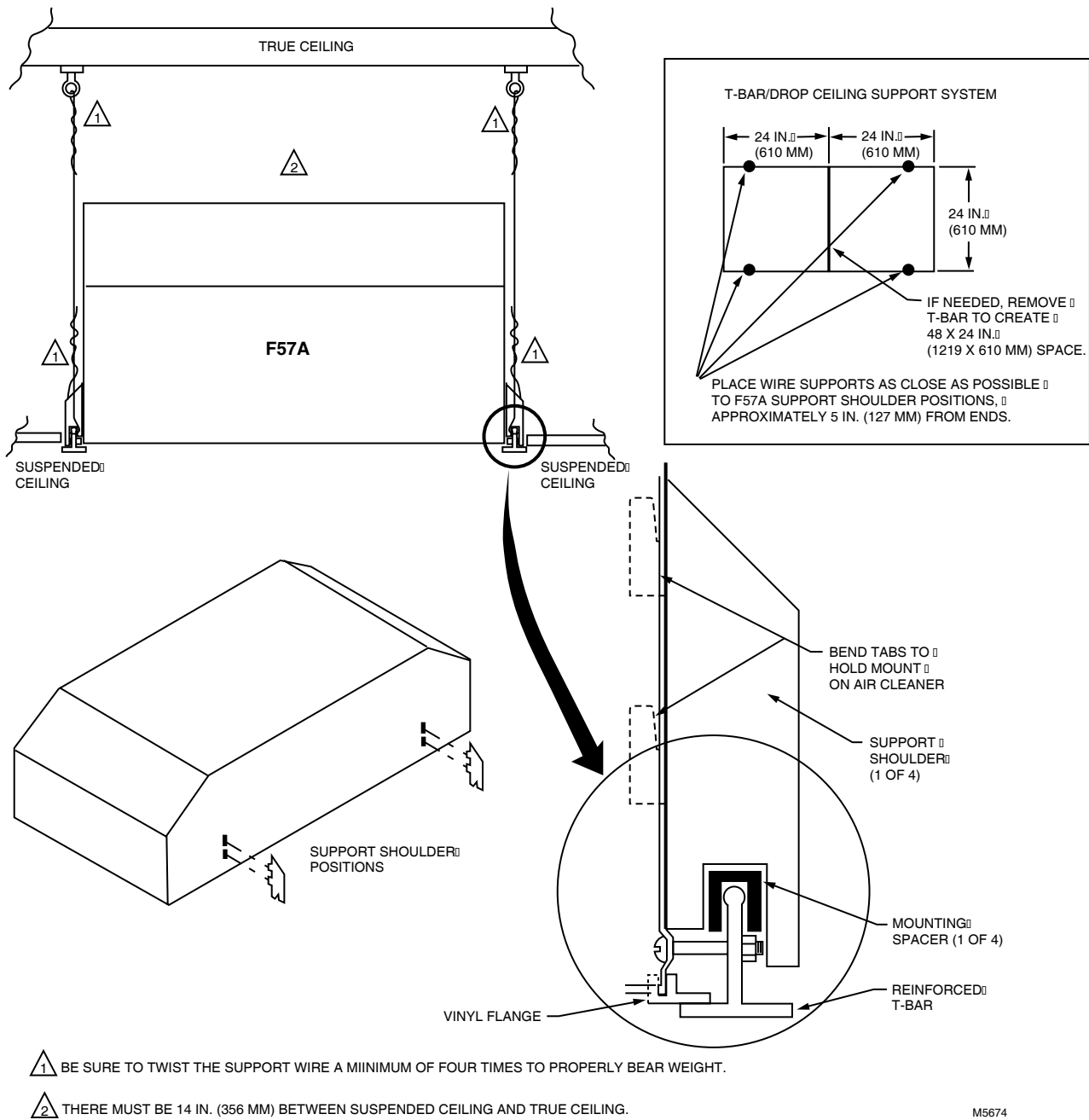

M5674

Fig. 5. Typical F57A mounting procedures.

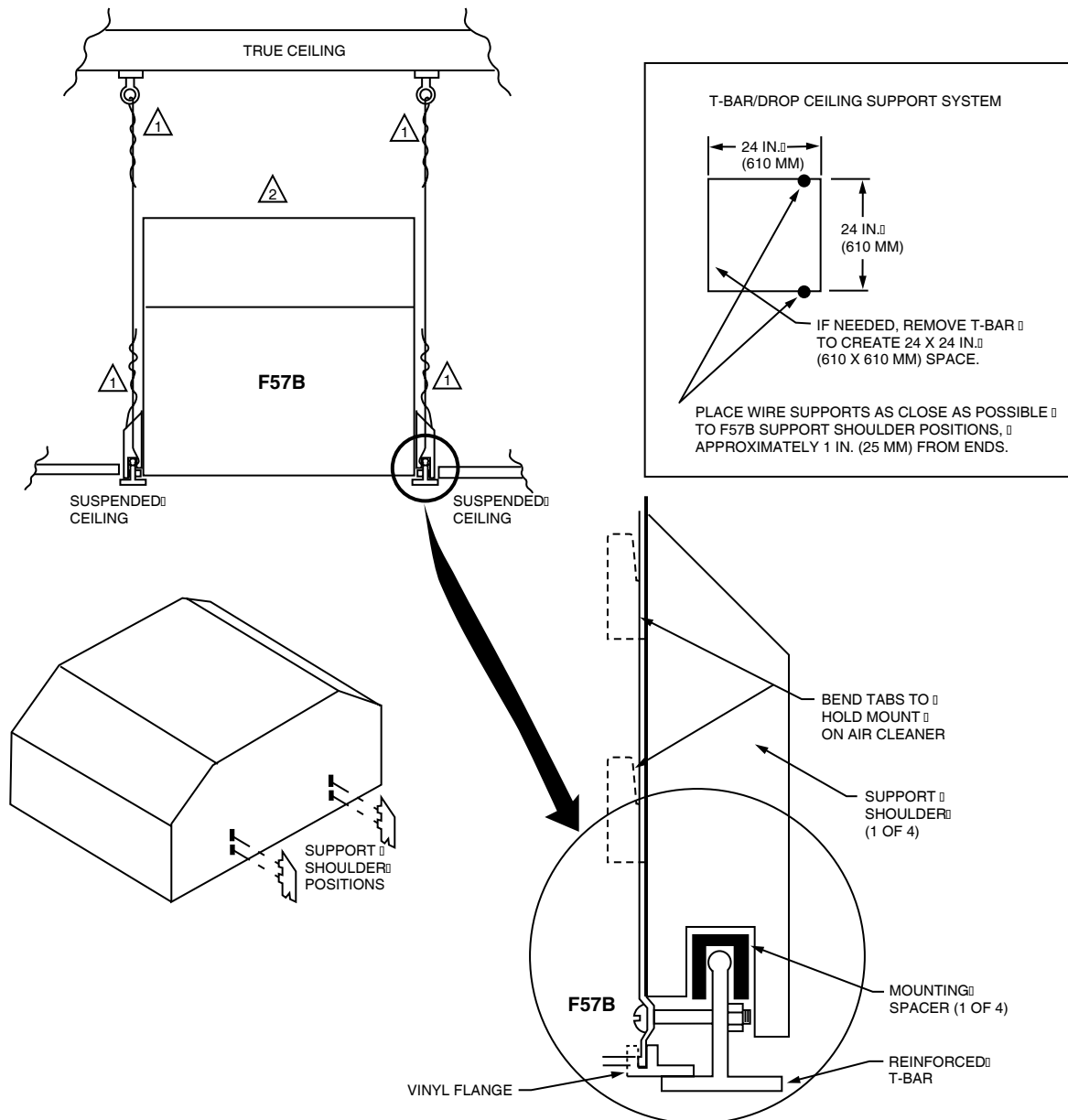

1 BE SURE TO TWIST THE SUPPORT WIRE A MINIMUM OF FOUR TIMES TO PROPERLY BEAR WEIGHT.

2 THERE MUST BE 14 IN. (356 MM) BETWEEN SUSPENDED CEILING AND TRUE CEILING.

M5675

Fig. 6. Typical F57B mounting procedures.

- Reinforce the suspended ceiling T-bars with the wire, placing the wires to evenly distribute the F57 weight. Securely attach wires to both the suspended ceiling and the true ceiling, and to the T-bars. Twist the wire at least four times.
- Place F57 into cleared area with grille side facing the floor. Lift F57 into space until grille side is above suspended ceiling level. Reach in and attach the rubber mounting spacers to the T-bars at the mounting shoulder locations.
- Attach four support shoulders to the F57. Bend the tab on the mounting shoulders to secure them to the F57.
- Attach vinyl flanges to the bottom of the F57 frame to cover any space that appears between the F57 and the suspended ceiling.
- Settle the F57 on the mounting spacers on the reinforced T-bars.
- Locate the holes just above the four vinyl flanges. Drill 1/4-in. (6.4 mm) holes through the T-bars at these locations. Slip a panhead bolt through each hole, and fasten with a self-locking nut.

Air Vent

The air vent helps to control gaseous contaminants such as by-products of cigarette smoking by allowing some of the air circulated through the F57 to be discharged into the return plenum.

To use the air vent, remove the five inch knockout in the side of the F57 cabinet. See Fig. 7. When venting into the false ceiling cavity, leave the vent fully open. When ducting into the return plenum, install damper and position it to reduce the opening by 50 percent.

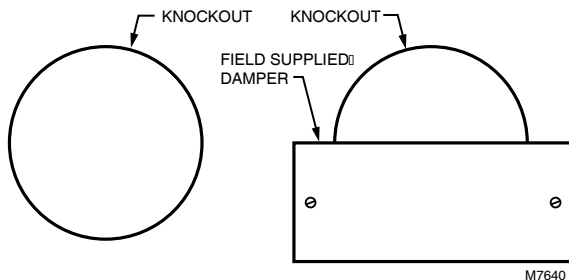

Fig. 7. Air vent adjustment.

Wiring

IMPORTANT

Before wiring the F57, remove the power supply cover. After completing the wiring procedures, reattach the power supply cover.

All wiring must comply with applicable codes and ordinances.

The power source to the F57A,B must agree with the model type, either 120 Vac, 60 Hz or 220–240 Vac, 50 Hz.

To wire 120 Vac, 60 Hz model:

- Run three No. 14 color-coded wires through the conduit to the wiring compartment of the F57. Attach the green wire to the external ground. The black and white wires are the power carriers.
- Attach the conduit to the knockout desired (either the large or small knockout).
- Attach the green ground wire to the ground screw. Ground the F57 for proper operation and safety.
- Attach the black and white wires to the black and white wires from the F57 using the wire nuts. See Fig. 8.

To wire 220–240 Vac, 50 Hz model, see Fig. 8.

IMPORTANT

Earth (ground) the F57 for proper operation and safety.

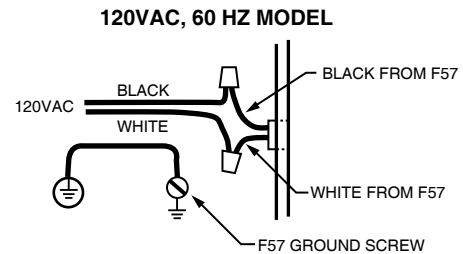

220-240VAC, 50 HZ MODEL

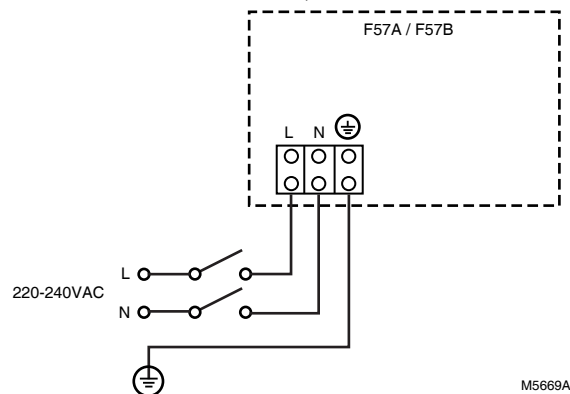

Fig. 8. Typical F57 wiring hookups.

Reassemble the F57

Reinstall the electronic cells, prefilter, charcoal filter (if used) and grille assembly. For proper installation of the cells, see Service section.

CHECKOUT

Inspect the Installation

Refer to Figs. 9 and 10 for location of components.

- Be sure that the screws on the back of the F57 are removed to allow for the motor floating suspension.
- Observe that the F57 is oriented for good air circulation.
- Check that the F57 is correctly and securely attached. Be sure that the F57 weight does not overstress the suspended ceiling.
- Make sure that the access door is easily opened, and that the prefilter, cells, and activated carbon filters (if used) are secure within the unit.
- Check leveling of the F57. If necessary, further reinforce and relevel suspended ceiling T-bar grid and adjust the hanging wires. If unit is not level, motor can be noisy or can eventually malfunction.
- Check that the electronic cells are correctly oriented for correct airflow. The cells are correctly oriented when the contact board of the cell is properly seated. The ionizer section faces the access door and the collector section faces the fan.

- Be sure the prefilter is correctly placed. The airflow arrow on the prefilter should be pointing toward the cells.
- Check that the wiring compartment cover is correctly reinstalled and the grille assembly is latched closed.
- Clean the inside and outside of the F57.

Check Air Cleaner Operation

- Push the test button to check the power supply. An audible arc indicates power supply operation. The CHECK LED lights.
- Check that the fan runs at all three speed settings and the ON LED lights when the fan is operating.
- Check that the WASH LED (if used) lights if the cells are removed with the grille closed and the F57 turned on.

SERVICE



WARNING

Sharp Edges

Can cause personal injury.

Wear protective gloves when handling the cells and prefilter to avoid cuts from the sharp metal edges, collection plates, and ionizer wires.

Hot Water, Strong Detergent

Can cause personal injury.

Wear rubber gloves, eye protection, and rubber apron for protection.

IMPORTANT

Electronic air cleaners and components are susceptible to damage. Be careful when working with them to avoid equipment damage. Detergents used for cell washing must never be acid based and must have inhibitors to prevent cell erosion.

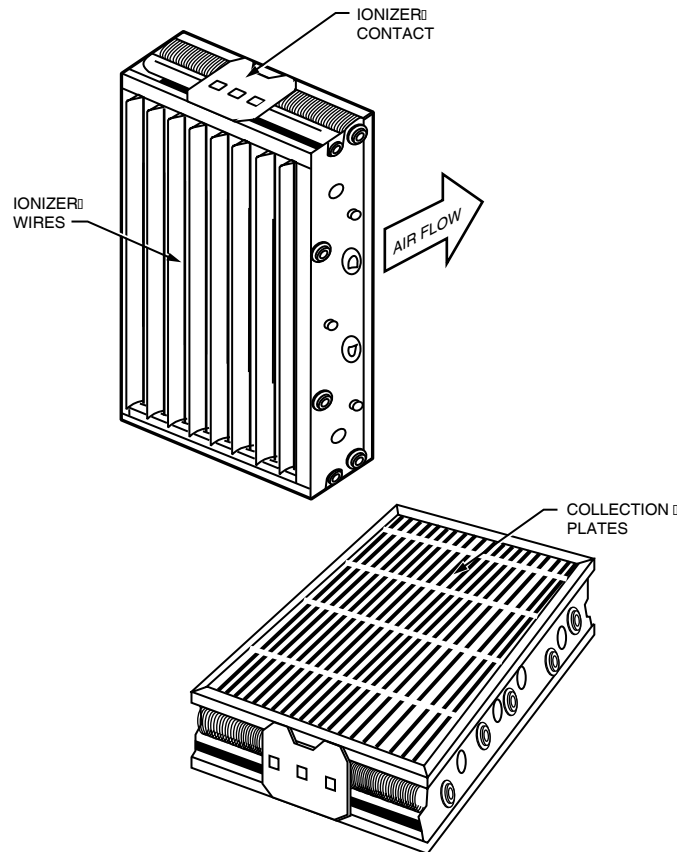

Fig. 9. FC37B Heavy Duty Commercial Cell.

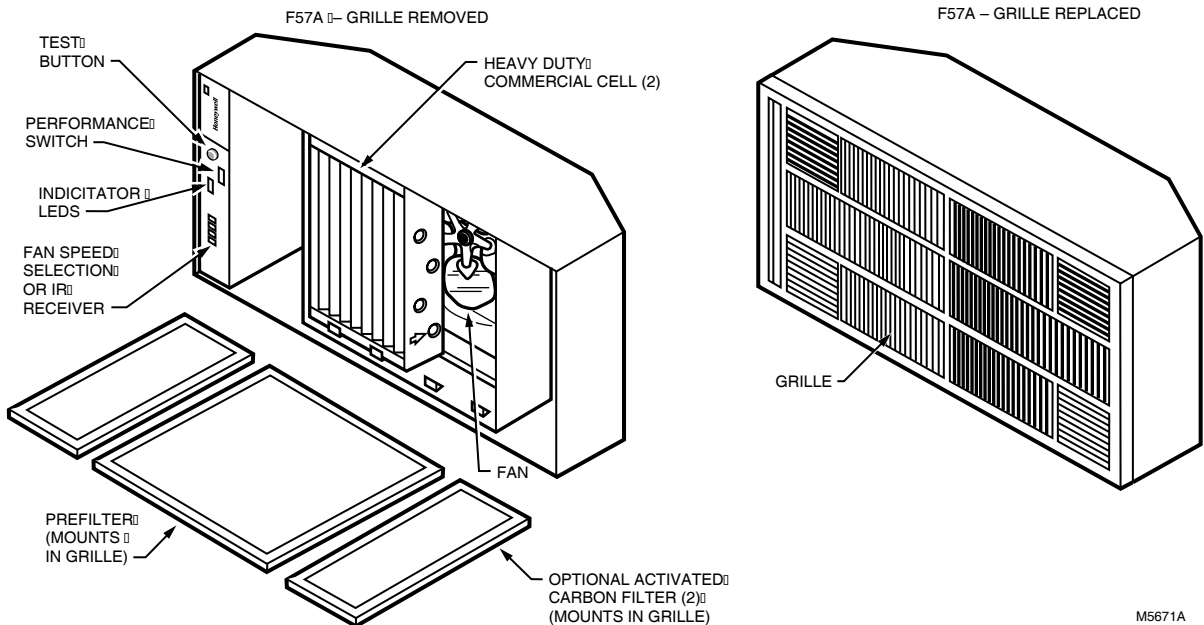

Fig. 10. F57 components (A model shown).

Cleaning the Commercial Electronic Air Cleaner

The F57 removes a variety of particulate contaminants from the air. In the process of cleaning the air, the air cleaner cells and prefilter become dirty, and the cleaning efficiency is lowered.

To maintain a high standard of reliability and efficiency, it is necessary to periodically maintain the F57. Maintenance includes cleaning the cells and prefilter and inspecting the F57. Service is required if the F57 is damaged, performs at substandard efficiency, measures abnormal voltages, or when the CHECK LED lights.

Regular cleaning with an alkaline-based detergent solution is recommended. Use a commercial or home electric dishwasher detergent, either liquid or powder. The wash frequency is determined by the dirt level in the air. Actual experience or optional WASH LED dictates the period between cleanings.

If the optional WASH LED is connected and the WASH LED comes on, a cell washing is overdue. Frequently wash the cells and wipe any material buildup off the ionizer wires. This prevents the wash led from coming on.

When washing with alkaline detergent results in excessive buildup of collected dirt in the cells, do an extended cell soaking. If buildup is still present, use high pressure water, or air or steam cleaning. Some full-service distributors provide a regular cleaning service to commercial establishments.

Opening the Grille

CAUTION

- Turn off power to the F57.
- Stand on a stable platform when working with the F57.

The F57 grille can be opened by moving the spring clips toward each other.

Removing the Heavy Duty Commercial Cells and Prefilter

Remove the FC37B cells from the F57 as follows (Fig. 11):

- Turn off electrical power to the F57. Open the grille.

IMPORTANT

The cell swings down when unlatched.

- With one hand supporting the cell near the latch, rotate the latch to an open position.
- Gently lower the cell with both hands until the cell contact board is clear of the frame.
- Raise cell off hooks to free the cell.

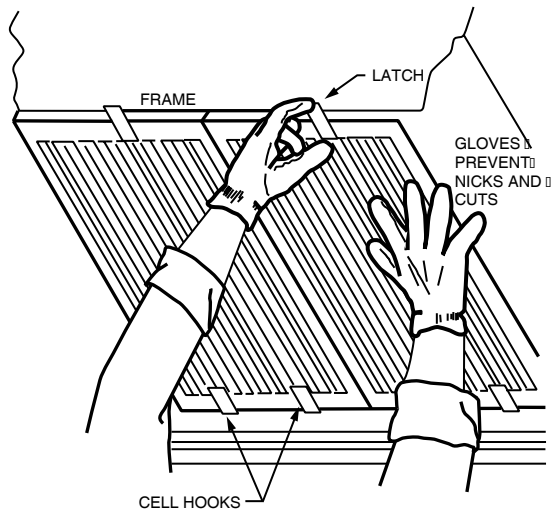

Fig. 11. Removing the FC37B Heavy Duty Commercial Cell (F57A model shown).

- Remove the prefilter from inside the grille.
- Remove the activated carbon filters, if used, only if it must be replaced. The odor removal effectiveness is reduced when the carbon is saturated with tobacco tar or other gaseous contaminants and can require replacement.

Cleaning the Prefilter

- Shake out or vacuum the accumulated contaminants from the prefilter. The prefilter can also be soaked in the alkaline detergent solution, as described for cleaning cells in the next section. When cleaning the prefilter, do not soak in an acid detergent solution, or use high pressure water, air or steam cleaning.

NOTE: When cleaning the prefilter, wash it after the cells are washed. The lint residue from the prefilter contaminates the wash water and can deposit inside the cells. Dispose of the wash water.

Cleaning the Cells Using Alkaline Base Detergent

WARNING

Hazardous Chemical.

Can cause personal injury.

- Use eye protection to prevent splashing the detergent solution in your eyes.
- Wear rubber gloves to avoid prolonged skin contact with the detergent.
- Keep detergent solution out of the reach of children.

- Provide a large enough container, such as a laundry tub or plastic tank, to hold at least one cell.
- Mix alkaline base detergent, such as commercial or home electric dishwashing detergent (either liquid or powder) with hot water. Follow the instructions on the detergent package. The water temperature should be between 150°F and 190°F (66°C and 88°C). When using a cold water detergent, follow instructions included with the detergent.

NOTE: Be sure to avoid prolonged skin contact with the solution. Do not splash solution in eyes.

- Soak the cells in the solution for up to 15 minutes; agitate the cells up and down. See Fig. 12.

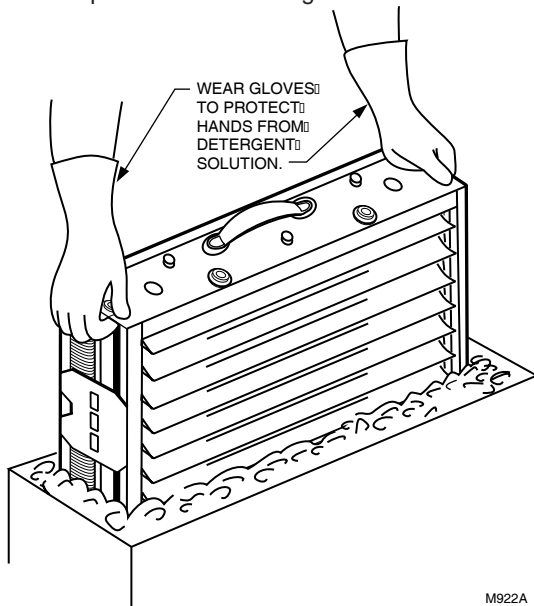

Fig. 12. Agitate the cells in the water.

- Remove the cells from the detergent solution; spray with hot water as a prerinse, if desired and place cells in another container of clear hot water (150°F to 190°F [66°C to 88°C]) for final rinsing. Rinse the cells for five to ten minutes.
- Remove the cells from the rinse water. Allow the cells to drain and dry before energizing them. For optimum water drainage from tubes, stand the cell on one of its corners.
- Wipe ionizer wires to remove any deposits remaining on the wires.
- Check the collection plates of the cells for any detergent residue. Repeat the rinse process if there is any residue remaining. Buildup can reduce the F57 efficiency.

About Discolored Aluminum

Occasionally, the cell or prefilter can seem stained after the soaking process. When the stain is black or very dark, it is probably dirt residue and the cell should be rewashed. White detergent residue can also affect the F57 efficiency and should be rinsed off. When yellowing appears, it is probably staining from tobacco smoke or other airborne dirt. Moderate discoloration does not affect the F57 efficiency.

Cleaning the Cells Using Air Pressure, Water Pressure or Low Pressure Steam

The following alternative methods can be used to clean some contaminants from the F57 cells. See Fig. 13. To prevent damage to the prefilter, do not use pressure or steam methods on the prefilter.

- *High Pressure Air or Water.* Care should be taken to avoid damage to the cells. If detergent is required with the high pressure water, use an alkaline base detergent. Do not use an acid detergent.
- *Steam.* Extreme care must be taken when steam cleaning to avoid warping or bending the collector plates of the cells. Remember that the cells are hot after steam cleaning and care must be taken to avoid burns. Use only low pressure or wet steam.

NOTE: Do not use steam at pressure greater than 5 psi (35 kPa) or temperature hotter than 250°F (121°C).

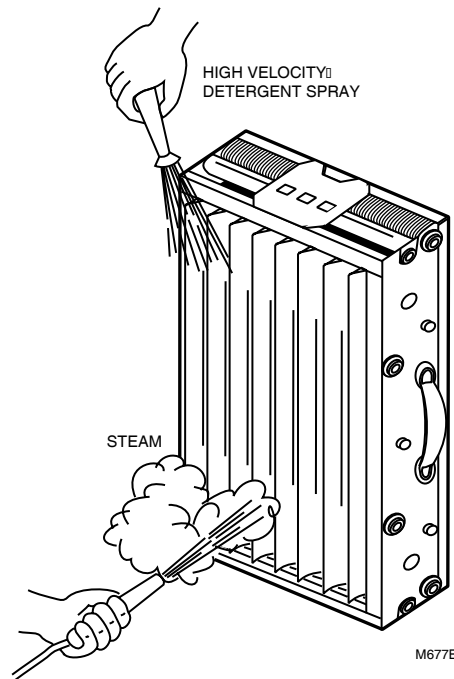

Fig. 13. It can be necessary to steam or use high pressure to remove collected cells contamination.

Removing Specific Contaminants from Cells

The following list gives the appropriate cleaning procedure for types of contamination often found on cells and prefilters. Cleaning procedures are listed in order of preference. Be careful to avoid bending the cell collector plates.

Contaminant	Cleaning Procedure
Animal hair solution	Dishwasher detergent
Carbon (carbon black, soot, lamp black, graphite, charcoal dust)	Dishwasher detergent solution high pressure air* or high pressure water*
Cooking oils: Vegetable (Soybean, peanut) Animal (lard, butter)	Dishwasher detergent solution or steam*
Cotton fibers solution	Dishwasher detergent solution
Dust (silicon dioxide, calcium carbonate, and mineral type compounds)	Dishwasher detergent solution
Flour dust	Dishwasher detergent solution
Mineral oil (petroleum base, diesters and silicone)	Dishwasher detergent solution or high pressure water*
Paper products	Dishwasher detergent solution
Paint (oil base or water base)	Dishwasher detergent solution
Pine tar resins	Dishwasher detergent solution or steam*
Soaps	Dishwasher detergent solution
Sodium chloride	Dishwasher detergent solution
Sugars (all types including molasses)	Dishwasher detergent solution or steam*
Talc	High pressure air* or Dishwasher detergent solution
Tobacco tars and smoke	Dishwasher detergent solution
Varnishes	Dishwasher detergent solution
Waxes (all types)	Dishwasher detergent solution or steam*
* Do not use to clean prefilters.	

Reinstalling the Cells, Prefilter and Activated Carbon Filters, If Used

- Inspect the cells for broken ionizer wires and bent collector plates. Bend warped or bent collector plates back into shape. For maximum efficiency, replace broken ionizer wires as instructed in Replacing Ionizer Wires section.
- Wipe ionizer wires.
- Check that cells are completely dry before reinstalling in the air cleaner. If cells are placed into the air cleaner while still wet, the electronic cells can short out and arc frequently when almost dry. Although the system appears to be operating, the cells may not be cleaning during the drying period.
- Be sure the contact board of the cell is facing the latch side of the frame.
- Check that the airflow arrow is pointing toward the fan. In this position, the ionizer wire side of the cell is the farthest from the fan.
- Ease the edge of the cell into the cell hooks.
- Using both hands, pivot the cell until the contact board mates with the frame.
- With one hand supporting the cell near the latch, rotate the latch to a closed position. See Fig. 14.
- Wipe surface dirt from the inside and the outside of the grille.
- Replace the prefilter in the grille. Be sure that the airflow arrow is pointing toward the cells.
- Replace activated carbon filters, if used. The F57A carbon filters fit inside the grille, one on each side of the prefilter. The F57B carbon filter fits inside the grille on the left side of the prefilter.
- Close and carefully latch the grille.

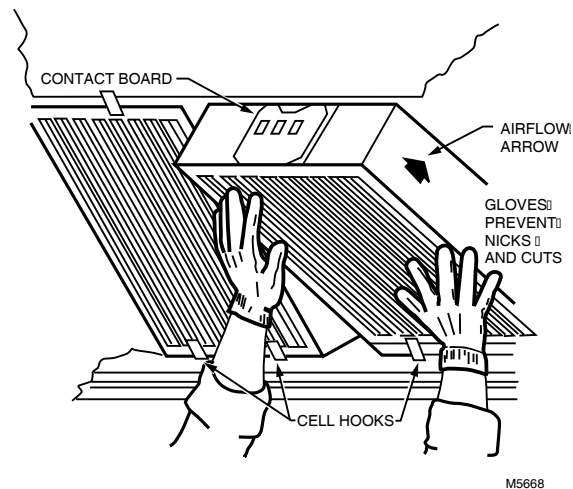

Fig. 14. Reinstalling the cell.

Replacing Ionizer Wires

Broken or bent ionizer wires can cause an electrical short to ground, often resulting in visible arcing or sparking. Remove broken wires. Cells can be used temporarily with one wire missing, but replace the wire as soon as possible.

Replacement wires, part no. 136434AA, are cut to length with eyelets on both sides for easy installation. To install:

1. Hook the eyelet on one end of the wire over the spring connector on one end of the cell. See Fig. 15. Be careful to avoid damaging the spring connector or other parts of the cell.
2. Hold the opposite eyelet with a needlenose pliers and stretch the wire the length of the cell. Depress the opposite spring connector and hook the eyelet over it.

3. Check the cell for short circuits using an ohmmeter. See Fig. 16. Check the resistance between the frame of the cell and both the ionizer and the collector contacts. In each case, the resistance should be infinite.

REPLACING AN IONIZER WIRE.

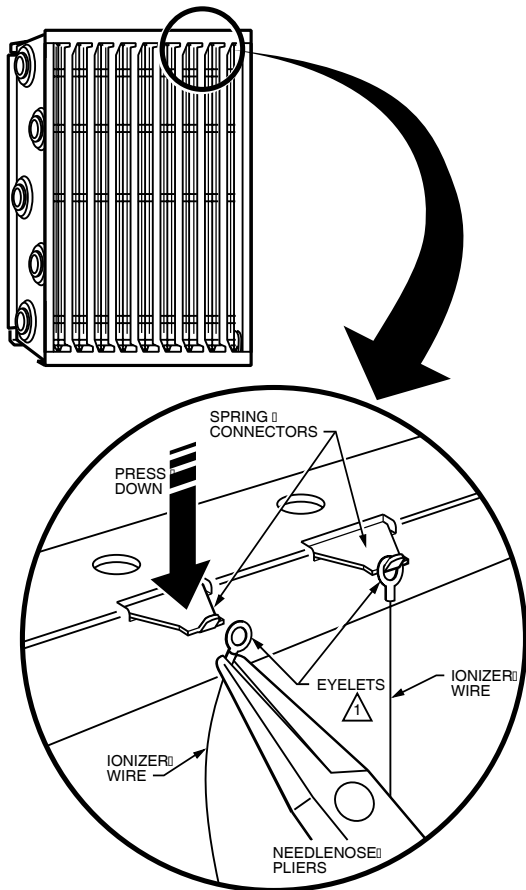

⚠ TWO EYELETS HOLD IONIZER WIRE TO CELL. M1540B

Fig. 15. Install new ionizer wire by hooking eyelets over spring connectors.

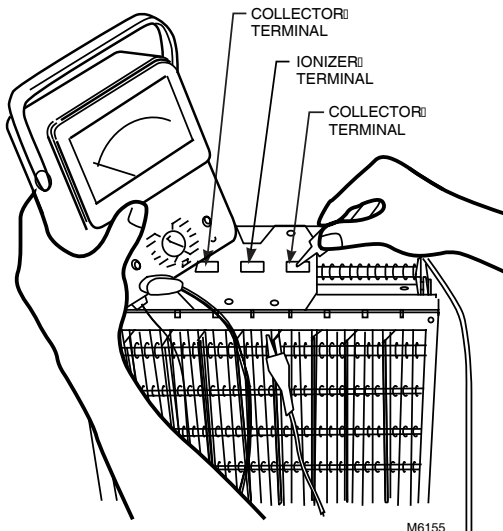

Fig. 16. Use an ohmmeter to check the cells for short circuits.

Modification to Reduce Ozone Odor

The electronic air cleaner generates a trace amount of ozone in normal operation. During the first week or two of operation, the amount may be higher because of sharp edges on some of the new high voltage metal parts. However, normal use and the first wash quickly dull the edges.

The average person can detect the odor of ozone indoors in concentrations as low as 0.003 to 0.010 parts per million (ppm). The electronic air cleaner contributes 0.005 to 0.010 ppm of ozone to the indoor air. The U.S. Food and Drug Administration and Health and Welfare Canada recommend that indoor ozone concentration should not exceed 0.050 ppm. As a comparison, the outdoor ozone level in major cities ranges from 0.020 ppm to 0.040 ppm and even higher.

However, if desired, the ozone generated by the air cleaner can be reduced in one of two ways:

1. Install the optional activated carbon filter.
2. Open the grille and move the electronic air cleaner performance switch to the low setting. Close and relatch the grille. The cleaning efficiency is now reduced 5 to 15 percent, depending on airflow.

NOTE: Be sure the switch is set to either high or low position, not between or the unit may not run. Be careful not to reset the switch when closing the cover.

ELECTRICAL TROUBLESHOOTING

⚠ WARNING

Electrical Shock Hazard
Can cause personal injury or equipment damage. The following procedures expose hazardous live parts. Disconnect power supply between checks and proceed carefully.

⚠ CAUTION

The following instructions are for use by only qualified personnel.

Tools and Equipment

- Troubleshooting the electronic air cleaner requires:
- Needlenose pliers for stringing ionizer wires and inserting edge connectors.
 - Test meter with 15 kV dc probe.

Troubleshooting Procedure

The electronic air cleaner Troubleshooting chart, Fig. 17 shows how to quickly isolate a problem in the air cleaner. See Figs. 18 & 19 for electrical schematics.

F57A,B FLUSH-MOUNT COMMERCIAL ELECTRONIC AIR CLEANER

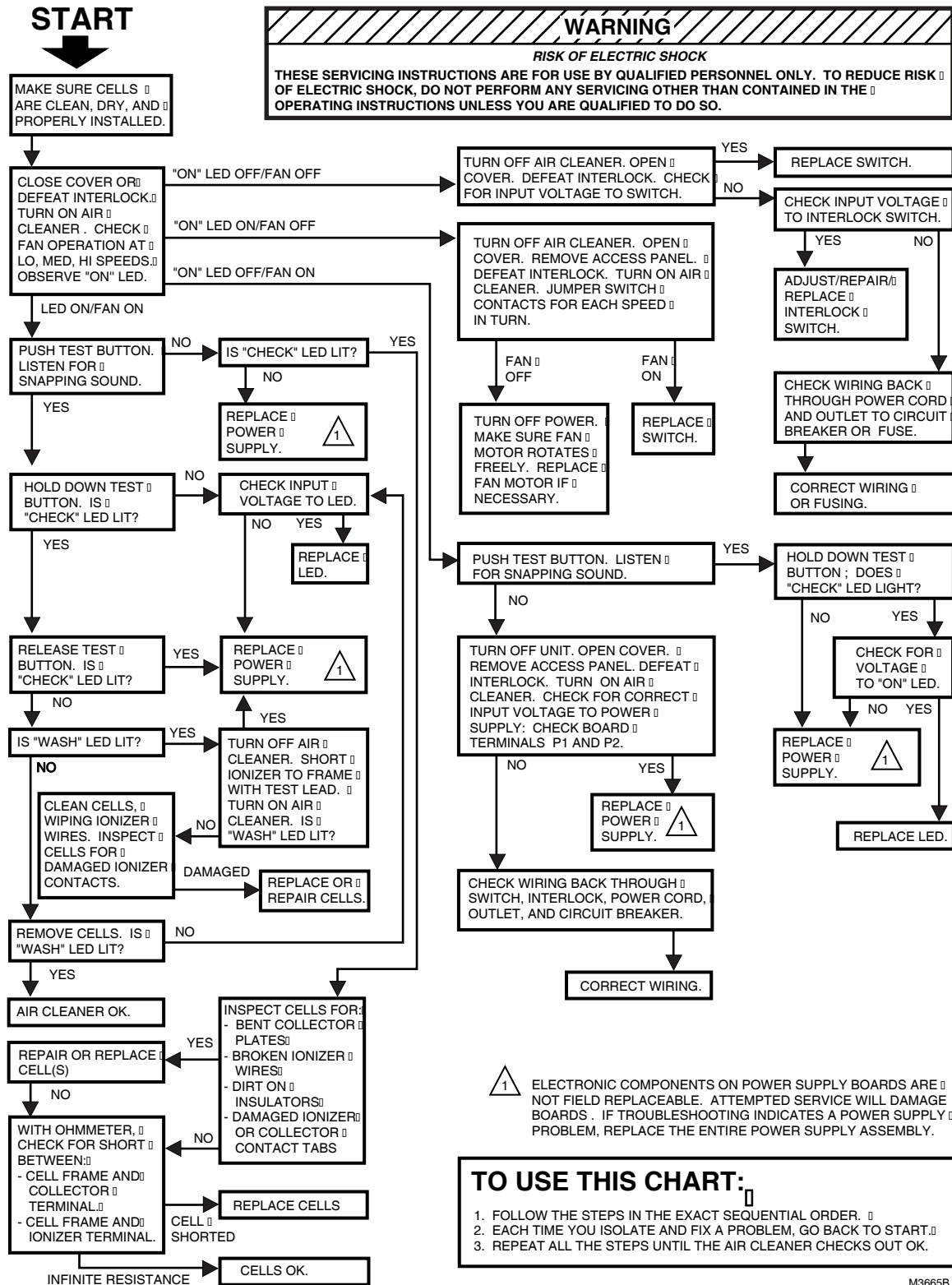
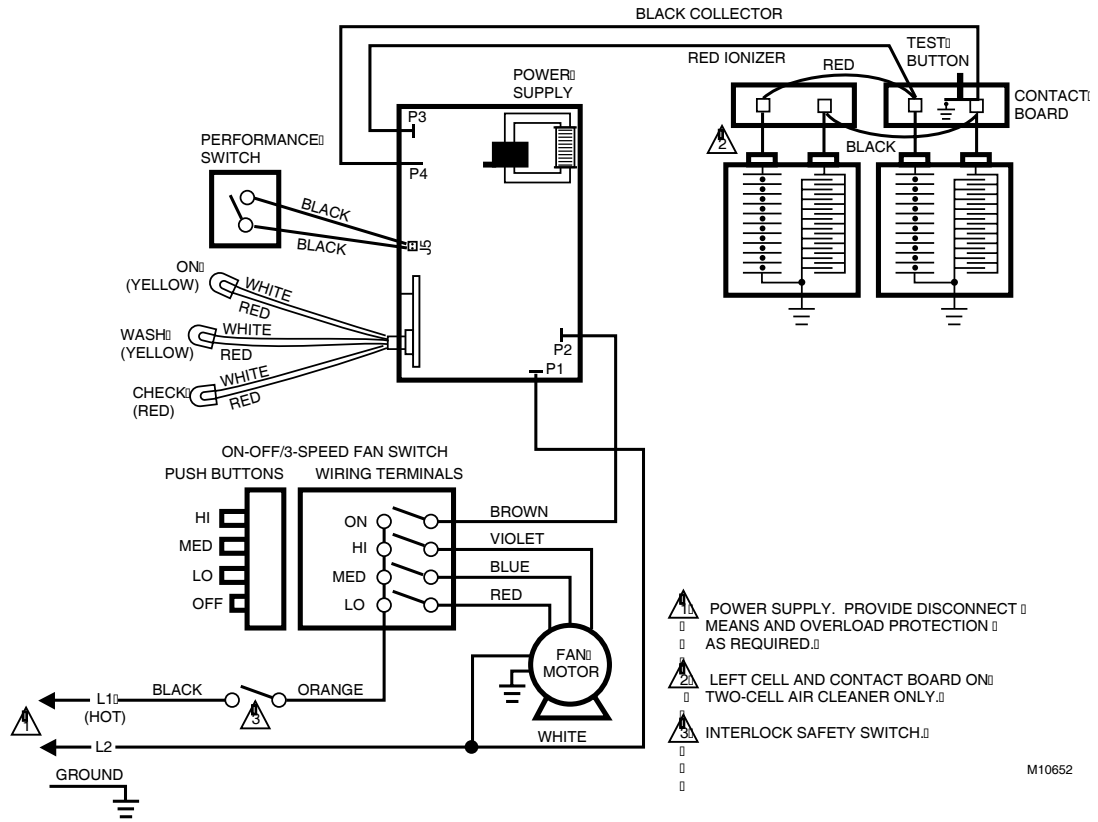

Fig. 17. Electrical troubleshooting procedure for the F57A,B.

F57A,B FLUSH-MOUNTED COMMERCIAL ELECTRONIC AIR CLEANER



M10652

Fig. 18. F57A,B 120V model electrical schematic.

F57A,B FLUSH-MOUNT COMMERCIAL ELECTRONIC AIR CLEANER

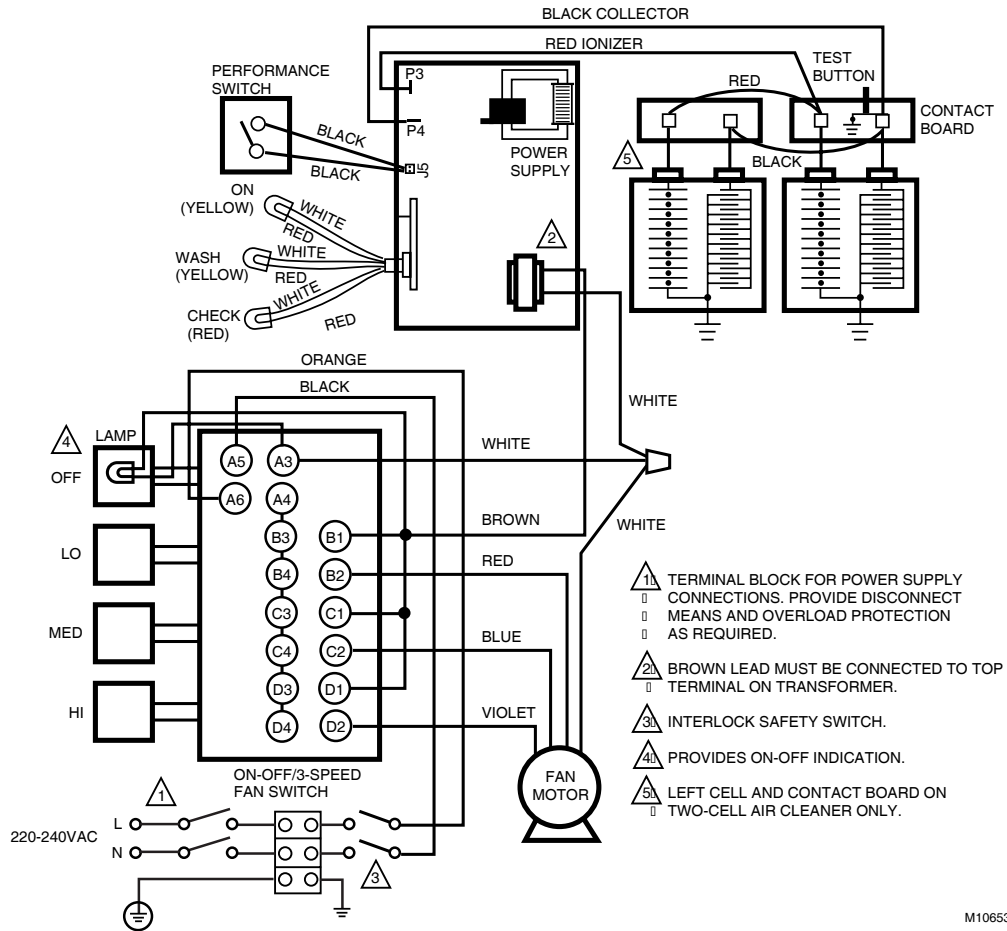

M10653A

Fig. 19. F57A,B 220-240V model electrical schematic.

PARTS LIST

See Fig. 20 for exploded view of parts listed.

Fig. Ref. No.	Description	F57 A Part Number		F57B Part Number	
		120 Vac, 60 Hz Model	220/240 Vac, 50 Hz Model	120 Vac, 60 Hz Model	220/240 Vac, 50 Hz Model
1	Grille Assembly	196411B	196411B	220364A	220364A
2	Prefilter	195910	195910	198571	198571
3	Heavy Duty Commercial Cell (two on F57A, 1 on F57B)	FC37B1030 (2)	FC37B1030 (2)	FC37B1030	FC37B1030
4	Fan	196205	196205	220393	220393
5	Motor Assembly (includes motor, motor bracket, four isolation bushings)	196215A	196216A	198673A	200813A
6	Control Switch	190382	196934	190382	196934
6a	Infrared Receiver *	203904A**			
7	Performance Switch	196214	196214	196214	196214
8	Interlock Switch	198671	196227	198671	196227
9	Power Supply Assembly	203361A 208427C *	203361B 208427Q	203361C 208427K *	203361D 208427T
10	Vinyl Strips (2)	196150	196413	196150	196413
11	Vinyl Strips (2)	196151	196414	198651	198651
12	Motor Bracket	2020791	2020791	2020791	2020791
INSTALLATION PARTS INCLUDED (NOT SHOWN)					
Shoulder Mounts (four required per unit for hanging)		196133		196133	
Rubber Mounting Spacers (two on F57A, one on F57B)		196134		196134	
PARTS AND OPTIONAL ACCESSORIES (NOT SHOWN)					
WASH LED Bag Assembly		4074EMH		4074 EMH	
Contact Board Assembly (two on F57A, one on F57B)		190912A		190912A	
Ionizer Wire (order in groups of five)		136434AA		136434AA	
Carbon Filter		195911 (2)		198672	
Hardwired Remote Control Assembly (for 120 Vac Model Only)		190097C		190097C	
Infrared Receiver/Transmitter Kit**		3604			
F57 Infrared Remote Cover Plate Kit		3605A M			
* Not available in Europe. ** Not Underwriter's Lab (U.L.) Certified					

F57A,B FLUSH-MOUNT COMMERCIAL ELECTRONIC AIR CLEANER

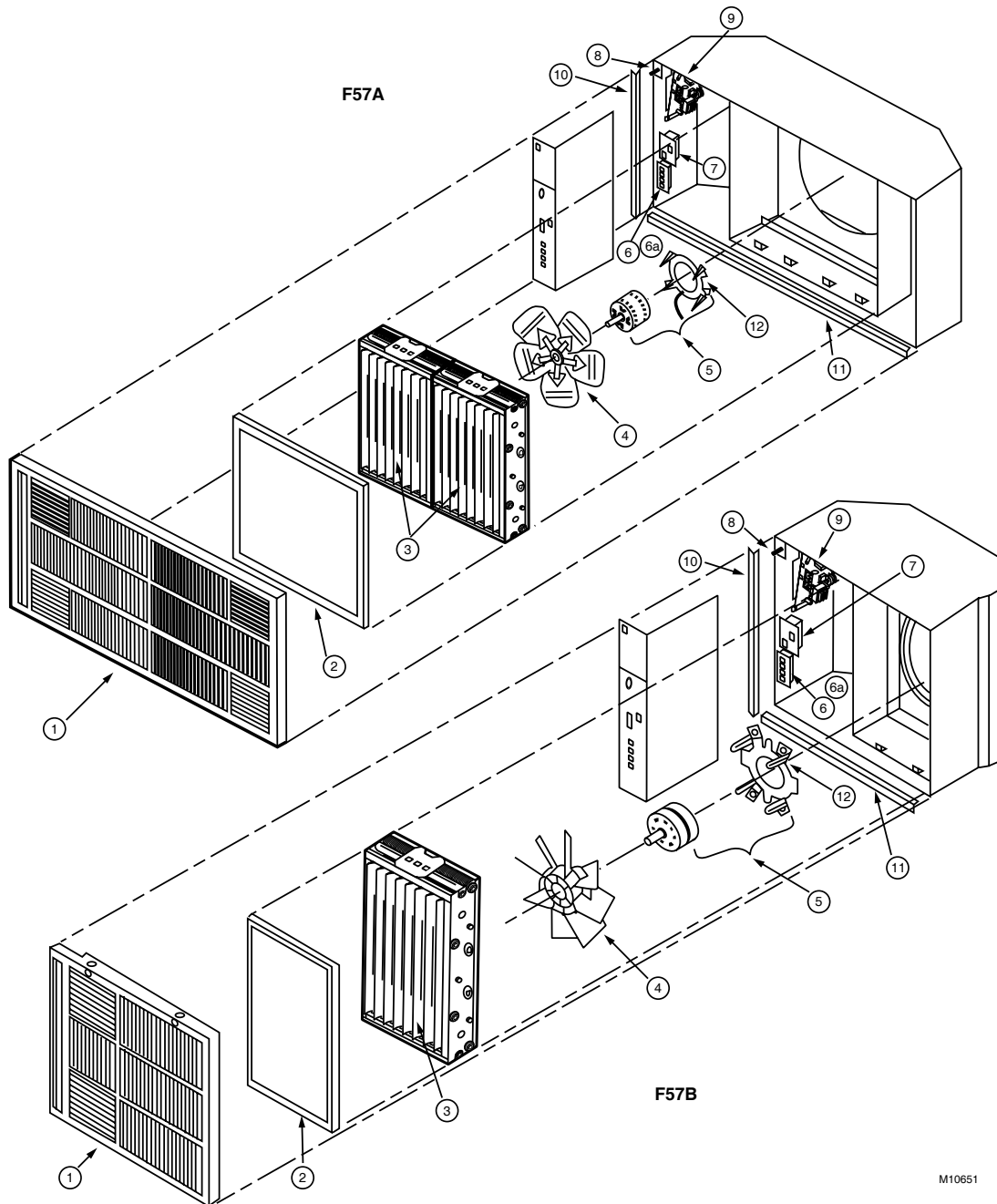

Fig. 20. Exploded view of F57A,B air cleaner components. Parts are keyed to the parts list on the previous page.

Notes

Notes

Notes

LIMITED ONE-YEAR WARRANTY

Air-Pure Systems warrants its air cleaner products to be free from defects in workmanship or materials under normal use and service, for a period of one (1) year from the date of purchase by the original end-user. If at anytime during the warranty period the product is defective or malfunctions, Air-Pure Systems, through the distributor or dealer, from which the product was purchased, or through an authorized warranty repair station, shall at Air-Pure Systems option, replace or repair the defective product or component.

This warranty does not cover removal or installation costs. This warranty shall not apply if it is shown that the defect or malfunction was caused by damage which occurred during handling or shipment, improper electrical connections, improper use of the product or abuse.

Air-Pure Systems sole responsibility shall be to repair or replace the product within the terms stated above. **AIR-PURE SYSTEMS SHALL NOT BE LIABLE FOR ANY LOSS OR DAMAGE OF ANY KIND, INCLUDING ANY INCIDENTAL OR CONSEQUENTIAL DAMAGES RESULTING, DIRECTLY OR INDIRECTLY, FROM ANY BREACH OF WARRANTY, EXPRESS OR IMPLIED, OR ANY OTHER FAILURE OF THIS PRODUCT.** (Some states do not allow the exclusion or limitation or incidental or consequential damages, so this limitation may not apply to you.). **THE WARRANTIES SET FORTH HEREIN ARE EXCLUSIVE AND AIR-PURE SYSTEMS EXPRESSLY DISCLAIMS ALL OTHER WARRANTIES, WHETHER WRITTEN OR ORAL, IMPLIED OR STATUTORY, INCLUDING BUT NOT LIMITED TO ANY WARRANTIES OR MERCHANTABILITY, WORKMANSHIP, OR FITNESS FOR A PARTICULAR USE.**

This warranty gives you specific legal rights and you may have other rights which vary from state to state.

How to make a warranty claim or have questions answered:

Should you have a warranty claim or questions about the warranty policy, contact the distributor or dealer from which you purchased the product or the authorized warranty repair stations nearest your location.

NOTE: Do not return any products or parts to the factory without a factory issued "Return Warranty Good Label" issued by Air-Pure Systems.

In the event you or other persons, have any questions concerning the use and care of this product of this warranty please call or write the factory.

Air-Pure Systems

16873 Fish Point Rd. SE
Prior Lake, MN 55372-1714
Phone: (800) 998-1919
Fax : (800) 221-3248

Air-Pure Systems

16873 Fish Point Rd. SE
Prior Lake, MN, 55372-1714
Phone: (800) 998-1919
Fax : (800) 221-3248